

CASIO FA-10

LINE SCALE	41
ALPHA SCALE	43
ALPHA ROTATE	44
SPACE	44
HORIZONTAL/VERTICAL PRINT	47
PRINT	48
MARK	50

CONTENTS

LINE FEED	44
HOME	44
TEST	44
TAB	44
FORMAT	44
PROGRAMMING EXAMPLES	44
HOW TO USE THE CASIO INTERFACE	44
Tape Recorder (TMR)	44
Precautions for Connecting Tape Recorder	44
Precautions for Recording and Playback	44
LOADING THE PAPER ROLL	44
WRITING/READING/CHAINING PROGRAM	44
WRITING/READING DATA	44
CHECKING FILES	44
HOW TO USE THE PLOTTER PRINTER	44
1. Character and Graphic Modes	44
2. Functioning in Character and Graphic Modes	44
3. Precautions on Switching Modes	44
4. Commands	44
CHARACTER CODE TABLE	44

INSTRUCTION MANUAL

The FA-10 is a compact plotter-printer with an interface to connect a cassette tape recorder.

To make the most of FA-10, read this manual carefully. For the basic operation and programming of the computer to be used with the FA-10, see the computer's Instruction Manual.

CONTENTS

HANDLING CAUTIONS	1
EACH SECTION'S NOMENCLATURE AND OPERATION	3
METHODS OF CONNECTION	5
Connecting the Computer	5
Connecting the Microcassette Tape Recorder (CMT)	5
POWER SUPPLY	6
LOADING THE PAPER ROLL	9
INSERTING/REMOVING PENS	11
CHECKING THE FUNCTIONS	13
HOW TO USE THE PLOTTER PRINTER	15
1. Character and Graphic Modes	15
2. Functioning in Character and Graphic Modes	15
3. Precautions on Switching Modes	15
4. Commands	16
5. Coordinate Systems	17
6. Formats for Commands and Their Parameters	19
7. Commands Affected as a Result of Status Modification by Other Commands	20
8. Errors	20

COMMANDS	21
ORIGIN	21
DRAW	22
RELATIVE DRAW	23
MOVE	24
RELATIVE MOVE	25
QUADRANGLE	26
CIRCLE	27
AXIS	29
GRID	30
LINE TYPE	31
LINE SCALE	32
ALPHA SCALE	33
ALPHA ROTATE	34
SPACE	35
HORIZONTAL/VERTICAL PRINT	37
PRINT	38
MARK	39
NEW PEN	40
LINE FEED	41
HOME	42
TEST	43
TAB	44
FORMAT	45
PROGRAMMING EXAMPLES	46
HOW TO USE THE CASSETTE INTERFACE	55
Tape Recorders Connectable to Plotter-Printer	55
Precautions for Connecting Tape Recorder	56
Precautions for Recording and Playback	56
WRITING/READING/CHAINING PROGRAM	58
WRITING/READING DATA	62
CHECKING FILES	64
COMMUNICATIONS BETWEEN TWO FA-10s	64
DATA COMMUNICATIONS	65
CHARACTER CODE TABLE	66
CHARACTER SAMPLES	67
COMMAND TABLE (FOR PLOTTER-PRINTER)	71
ERROR MESSAGES	74
SPECIFICATIONS	75

HANDLING CAUTIONS

- (1) This plotter-printer consists of precision electronic components. It must never be disassembled.
- (2) Avoid operating or storing the printer in an environment where the temperature is extremely high or low or where the temperature varies abruptly.
- (3) The printer must not be operated or stored in direct sunlight or close to any heating apparatus or in extremely humid or dusty environments.
- (4) Entry of any liquid or solid conductor (e.g., a piece of metal) into the printer is dangerous. If this occurs, turn off the power immediately and contact your nearest dealer.
- (5) Be sure to use the attached AC adaptor to connect the printer to the power supply.
- (6) Sharing the power receptacle with other equipment not only may cause malfunctioning of the printer but also is very dangerous.
- (7) Keep the POWER switch set to OFF when the printer is not in use. When the printer is not used for a long period of time, the AC adaptor should be unplugged.
- (8) Operating the printer close to a radio or television set may disturb normal reception.
- (9) To keep the printer clean, wipe its surface with a soft, dry cloth or one dampened with a neutral detergent. Do not use volatile solvents, such as paint thinner and benzine.
- (10) Any device (excepting a commercially available tape recorder) to be connected to the printer should be of CASIO make. CASIO will not be responsible for any damage to the printer due to use of any product of any other manufacturer.
- (11) Do not touch the connector portions: it may cause damage to the internal circuit due to poor contact or static electricity.
- (12) Never touch the moving part inside the printer, which is finely adjusted.
- (13) When the printer is not used for a long period of time, remove ball-point pens and store them with their cap on.
- (14) Applying excessive force to the paper roll during printer operation may cause uneven printouts.
- (15) Use consumable parts (paper rolls, pens, etc.) specified by CASIO. CASIO will not be responsible for any damage due to use of products of other manufacturers.
- (16) When the tape recorder is not in use, be sure to press the STOP button. Leaving the tape recorder in PLAY condition may cause the pinch rollers to deform, which in turn may cause a read/write error.
- (17) A read/write error occurs frequently when the tape recorder head is stained. Use a cleaning tape or cotton wound stick to clean the head.
- (18) Even when an external tape recorder is used, the CMT switch should be set to ON so as to permit the remote function to work.

- (19) When an external tape recorder is used, no signal sound can be heard even when the MONITOR switch is set to ON.
- (20) Cassette tapes not in use should be stored in a cassette case.
- (21) If any trouble should occur with the printer, contact your nearest dealer.
- (22) Before asking the dealer for repair, carefully check the power supply condition, the program, the operating procedure, etc., referring to this instruction manual.

EACH SECTION'S NOMENCLATURE AND OPERATION

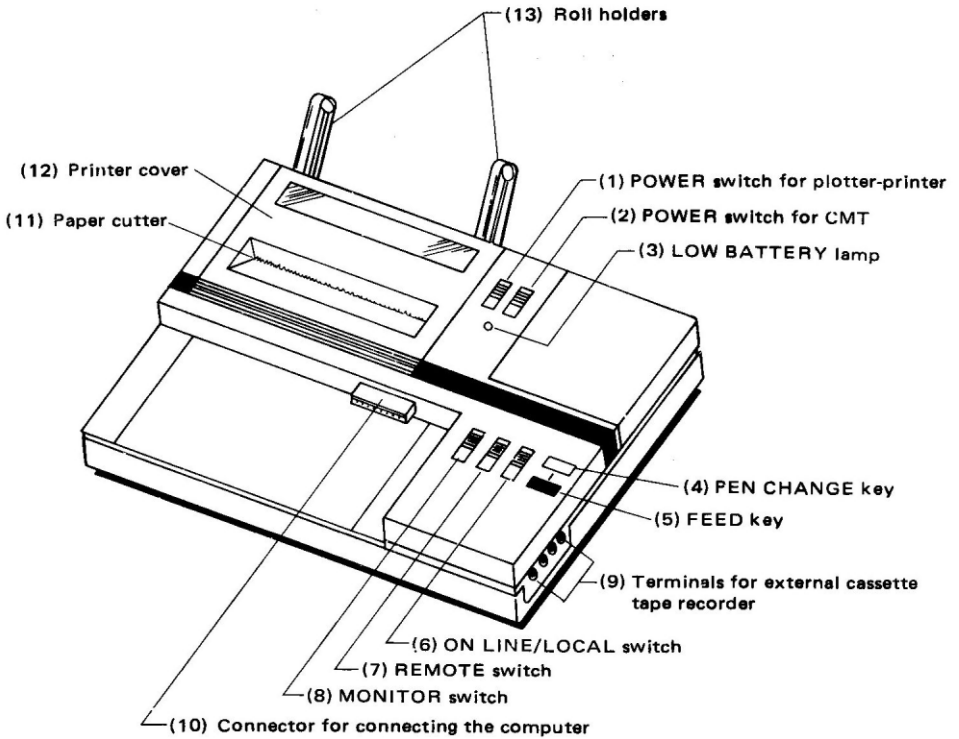

(1) POWER switch for plotter-printer

Set to ON when using the plotter-printer; set to OFF when not using the plotter-printer.

(2) POWER switch for CMT

Set to ON when using the tape recorder. When using an external tape recorder, this switch should also be set to ON so that the remote function can work. Set the switch to OFF when the tape recorder is not used.

(3) LOW BATTERY lamp

This lamp lights when the built-in Ni-Cd battery is running out. When the lamp lights, recharge the battery as soon as possible using the attached AC adaptor.

* When the POWER switches for printer and CMT are set to OFF, the lamp may flash even if the battery is fully charged.

(4) PEN CHANGE key

Press this key when changing the plotter-printer pen (see page 11). Note that this key works only when the POWER switch for printer is set to ON and the ON LINE/LOCAL switch is set to LOCAL.

(5) FEED key

Press this key to feed the roll of paper. This key works only when the POWER switch for printer is set to ON and the ON LINE/LOCAL switch is set to LOCAL.

(6) ON LINE/LOCAL switch

When this switch is set to ON LINE, the plotter-printer can receive data transferred from the computer. Keep the switch set to ON LINE during normal print operation. When the switch is set to LOCAL, the FEED and PEN CHANGE keys become effective, allowing to feed or change the paper roll or to change the pens.

(7) REMOTE switch

Set this switch to ON when remote-controlling start/stop of the tape recorder.

(8) MONITOR switch

Set this switch to ON when confirming the data signal sound (when the optional microcassette tape recorder, CM-1, is used).

Note that when an external tape recorder is used, no signal sound can be heard even if the switch is set to ON.

(9) Terminals for external cassette tape recorder

When using an external tape recorder or two FA-10s for data transfer, insert a mini-plug into the appropriate terminal.

OUT terminal: When two FA-10s are connected, connect this terminal with the EAR terminal of the other FA-10.

EAR terminal: When an external tape recorder is connected, connect this terminal with the EAR terminal of the tape recorder. When two FA-10s are connected, connect this terminal with the OUT terminal of the other FA-10.

MIC terminal: When an external tape recorder is connected, connect this terminal with the MIC terminal of the tape recorder.

REM terminal: When an external tape recorder is connected, connect this terminal with the REMOTE terminal of the tape recorder.

Note: When a plug is inserted into the EAR terminal, data cannot be read from the CM-1.

METHODS OF CONNECTION

■ Connecting the Computer

- (1) Turn off the power supply for the computer, plotter-printer, and CMT.
- (2) Remove the cap of the connector for connecting the computer.
- (3) Set the computer such that the concave section on the back of the computer is aligned to the convex section of the FA-10, then slide the computer in the arrow direction.

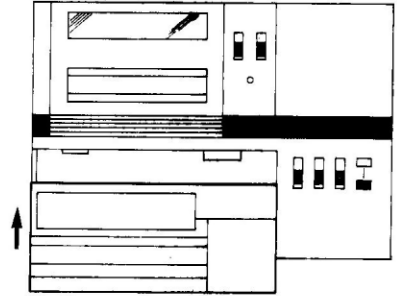

■ Connecting the Microcassette Tape Recorder (CMT)

- (1) Turn off the power supply for the computer, plotter-printer, and CMT.
- (2) Remove the two screws on the back of the FA-10 and remove the cover.
- (3) Connect the CMT connector to the FA-10 connector by sliding the CMT in the arrow direction.
- (4) Fix the CMT with the attached screws.

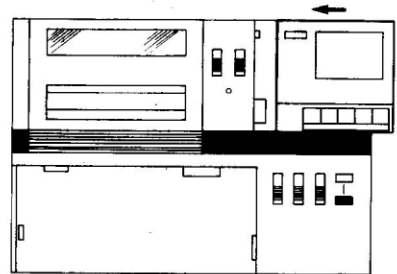
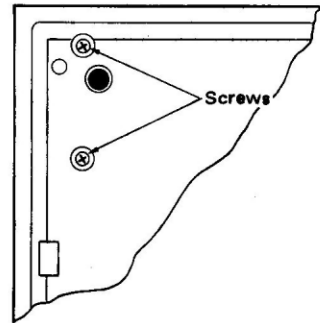

POWER SUPPLY

The plotter-printer is operated by a rechargeable battery. When the LOW BATTERY lamp lights, it indicates that the battery is running out. In this case, use the AC adaptor or recharge the battery.

The AC adaptor permits using the plotter-printer on an AC power supply. The battery is recharged if the printer and tape recorder are not used. When neither the printer nor the tape recorder is used, the battery is completely recharged in approximately 24 hours. (Recharging the battery for longer than 24 hours deteriorates the battery performance.)

■ Using the AC Adaptor

Connect the AC adaptor to the power receptacle and insert its plug into the jack of the plotter-printer.

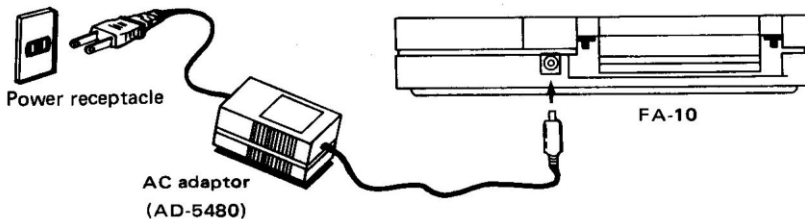

■ Notes on Using the AC Adaptor

- Be sure to use CASIO's AC adaptor. CASIO will not be responsible for any damage due to use of any other adaptor.
- Using an adaptor other than the attached one may cause the rechargeable battery to burst: it is very dangerous.
- The AC adaptor is slightly heated during operation. There is no need to worry about it. Disconnect the AC adaptor after recharging the battery or when the plotter-printer is not used.
- The battery incorporated in the plotter-printer may have been somewhat exhausted through self-discharging. Hence it should be recharged using the AC adaptor before using the plotter-printer for the first time.
- When left unused for an extended period of time, the battery may deteriorate in performance or leak its solution. Hence it should be recharged at least once every six months even if the plotter-printer is not used during that period. When the operating hours have noticeably decreased after recharging the battery several times, it indicates that the battery life is nearing to an end. In this case, contact your nearest dealer and replace the battery with a new one.

<Low-voltage detection feature>

The plotter-printer is provided with a low-voltage detection feature which indicates by a lamp that the battery voltage has dropped below a certain level.

When the LOW BATTERY lamp lights while the printer or tape recorder is being used (the switch set to ON), use the AC adaptor or recharge the battery.

Note that the lamp does not light when the battery is completely exhausted.

IMPORTANT SAFETY INSTRUCTIONS

(applicable in the U. S. A.)

1. **SAVE THESE INSTRUCTIONS** – This manual contains important safety and operating instructions for battery charger Model AD-5480.
2. Before using battery charger, read all instructions and cautionary markings on (1) battery charger, (2) battery, and (3) product using battery.
3. **CAUTION** – To reduce risk of injury, charge only Nickel-Cadmium type rechargeable batteries. Other types of batteries may burst causing personal injury and damage.
4. Do not expose charger to rain or snow.
5. Use of an attachment not recommended or sold by the battery charger manufacturer may result in a risk of fire, electric shock, or injury to persons.
6. To reduce risk of damage to electric plug and cord, pull by plug rather than cord when disconnecting charger.
7. Make sure cord is located so that it will not be stepped on, tripped over, or otherwise subjected to damage or stress.
8. An extension cord should not be used unless absolutely necessary. Use of improper extension cord could result in a risk of fire and electric shock. If extension cord must be used, make sure:
 - a. That pins on plug of extension cord are the same number, size, and shape as those of plug on charger;
 - b. That extension cord is properly wired and in good electrical condition; and
 - c. That wire size is large enough for AC ampere rating of charger as specified in the following table.

RECOMMENDED MINIMUM AWG SIZE FOR
EXTENSION CORDS FOR BATTERY CHARGERS

AWG Size of Cord			
Length of Cord, Feet			
25	50	100	150
18	18	18	16

9. Do not operate charger with damaged cord or plug – replace them immediately.
10. Do not operate charger if it has received a sharp blow, been dropped, or otherwise damaged in any way; take it to a qualified serviceman.
11. Do not disassemble charger; take it to a qualified serviceman when service or repair is required. Incorrect reassembly may result in a risk of electric shock or fire.
12. To reduce risk of electric shock, unplug charger from outlet before attempting any maintenance or cleaning. Turning off controls will not reduce this risk.

LOADING THE PAPER ROLL

- (1) Set the plotter POWER switch to ON and the ON LINE/LOCAL switch to LOCAL.
- (2) Cut across the paper to form a clean end (Fig. 1).

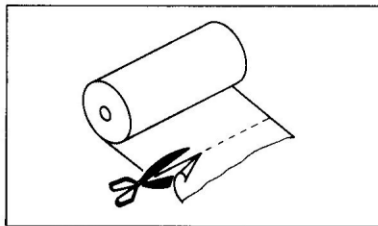

Fig. 1

- (3) Remove the printer cover by sliding it backward (Fig. 2).

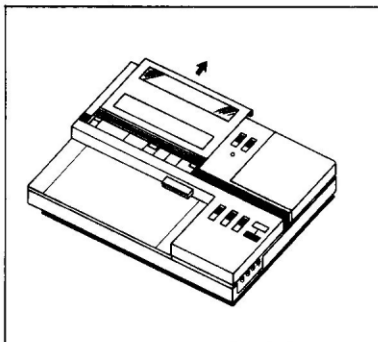

Fig. 2

- (4) When a 70 mm ϕ paper roll is used, set the two roll holders and pass the leading end through the outer paper slot, then through the inner slot (Fig. 3).

* Be sure to remove the printer cover before inserting the roll holders into or removing from their mounting brackets.
To remove the roll holder, lift it off while pressing its catch.

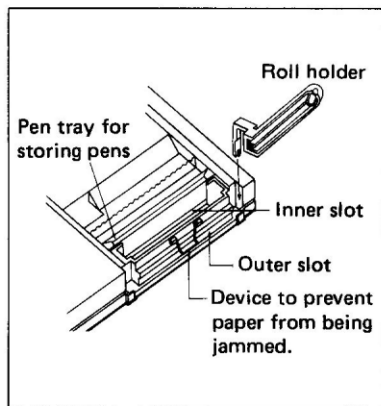
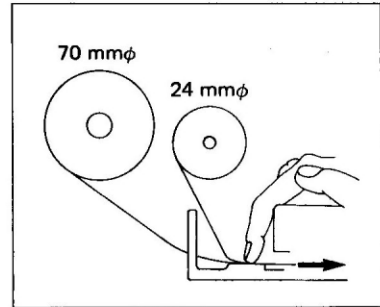

Fig. 3

- (5) When a 24 mm ϕ paper roll is used, pass the leading end of the paper through the inner slot.
- (6) Press the FEED key while lightly pushing the paper toward the inner slot.
- (7) When the leading end of the paper comes out of the paper cutter, set the paper roll on the roll holders (or inside the printer) and replace the printer cover. (When replacing the printer cover, pay attention to the device to prevent paper from being jammed.)



Notes:

- When pulling out the paper roll, cut the leading end of the paper with the paper cutter and pull the paper in the direction opposite to when the paper was inserted.
- Greased or sweated paper may cause uneven printouts, hence should be cut off. When loading a new roll, cut off the portion approximately 20 cm from the leading end after feeding: the outermost portion is apt to get smudged during loading.
- When ordering paper rolls, specify 'paper roll for FA-10': PRP-24 (24 mm ϕ) or PRP-70 (70 mm ϕ).

INSERTING/REMOVING PENS

<Inserting the pen>

- (1) Set the plotter POWER switch to ON and the ON LINE/LOCAL switch to LOCAL.
- (2) Remove the printer cover by sliding it as shown in Fig. 1.
- (3) Press the PEN CHANGE key to move the pen holder assembly to the right. Then, keep pressing the PEN CHANGE key until the pen to be changed comes on top.
- (4) Before inserting a new pen, check that it writes smoothly (Fig. 2). Trial plotting command (see page 43) is available to ensure clear printouts.
- (5) Holding the new pen, insert its tip into the retaining spring ring from beneath the pen holder and push the pen in the holder while keeping the pen holder assembly from rotating (Fig. 3).
 - * Do not reverse the direction in which the pen is inserted.
 - * Check the color markings on the pen holder assembly for correct pen setting (Fig. 4).

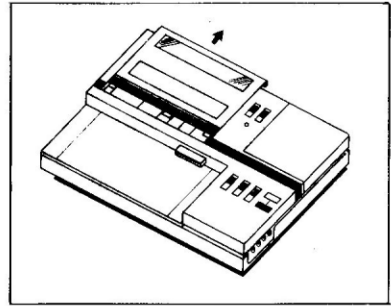

Fig. 1

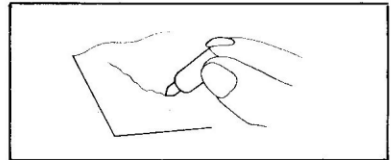

Fig. 2

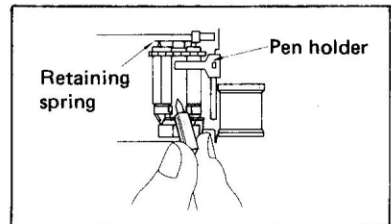

Fig. 3

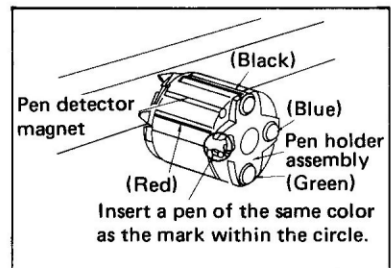
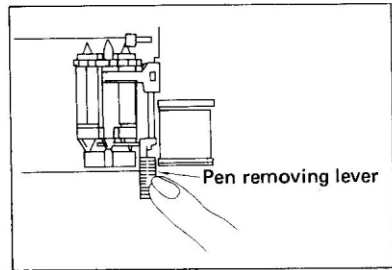

Fig. 4

- (6) Replace the printer cover.
 - * If the paper end gets beneath the printer cover guide, pull the paper slightly so that the cover can be properly replaced.
- (7) Pressing the FEED key automatically moves the pen holder assembly to the left end.

<Removing the pen>

- (1) Set the plotter POWER switch to ON and the ON LINE/LOCAL switch to LOCAL.
- (2) Remove the printer cover by sliding it as shown in Fig. 1.
- (3) Press the PEN CHANGE key, and the pen holder assembly moves to the right. Keep pressing the PEN CHANGE key until the pen to be changed comes on top.
- (4) Pull the pen removing lever, and the pen is disengaged from the groove. Carefully take out the pen from the assembly.



Notes:

- When replacing pens, do not apply excessive force to the pen holder assembly and lever: it may impair the accuracy of plotting.
- If a pen drops into the printer, it is ejected from the opening in the lower part of the printer case. Do not turn the printer upside down or swing it to take out the pen.
- When the printer will not be used for a long time, remove all four pens and store them with their cap on to prevent the ink from drying up.
- When ordering pens, specify 'pens for FA-10': BP-1 (black, blue, green and red) or BP-2 (black x 4).

CHECKING THE FUNCTIONS

1. Self-Checking

This plotter-printer has a built-in self-checking feature which can be used to test its functions before connecting it to the computer and before using it for printing.

How to use the self-checking feature:

Set the plotter POWER switch to ON while simultaneously pressing the FEED key.

Self-checking results:

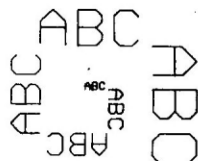
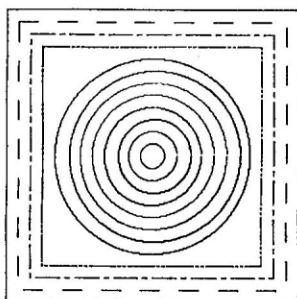

! " # \$ % & ' () * + , - . /
0 1 2 3 4 5 6 7 8 9 : ; < = > ?
@ A B C D E F G H I J K L M N O
P Q R S T U V W X Y Z [\] ^ _
` a b c d e f g h i j k l . m n o
p q r s t u v w x y z { | } ~
_ _ _ _ _ _ _ _ _ _ | | | | | | | | | | +
+ + + + + + + + + + | | | | | | | | | |)
。 「 」 、 ・ ヲ ア イ ウ エ オ ヤ ユ ヲ ッ
- ア イ ウ エ オ カ キ ク ケ コ サ シ ス セ ソ
タ チ ツ テ ト ナ ニ ネ ノ ハ ヒ フ ヘ ホ マ
ミ ム モ ヤ ヲ ヨ ラ リ ル レ ロ ワ ン ム
= 卍 卍 卍 ▲ ▼ ◆ ♡ ◆ ♡ ● ○ /
× 卍 年 月 日 時 分 秒 十 市 区 町 村 人 固

HOW TO USE THE PLOTTER-PRINTER

1. Character and Graphic Modes

The plotter-printer can operate in two modes: character (or print) mode and graphic mode. Either of these may be selected by a pair of command codes.

- Character mode selection codes: CHR\$ (28); CHR\$ (46)
Example: LPRINT CHR\$ (28); CHR\$ (46)
- Graphic mode selection codes: CHR\$ (28); CHR\$ (37)
Example: LPRINT CHR\$ (28); CHR\$ (37)
* No terminator (CHR\$ (1) – CHR\$ (31) function code) is required to switch operating modes.

2. Functioning in Character and Graphic Modes

(1) Character mode

In the character mode, the printer prints codes sent to it as characters.

When the pair of codes (CHR\$ (28); CHR\$ (46)) is received while in the graphic mode, the printer is switched to the character mode. It is also initialized to this mode when it is turned on.

Printing takes place when a function code other than CHR\$ (0) (i.e., CHR\$ (1) to CHR\$ (31)) is received or the buffer becomes full. When the sequence of function codes CR(CHR\$ (13)), LF(CHR\$ (10)) or a CR (in the auto-feed mode) is received, a carriage return takes place, followed by a line feed.

(2) Graphic mode

In this mode, the printer looks upon codes sent to it as graphic commands for plotting graphics.

Each graphic command is terminated with a terminator (a function code from CHR\$ (1) to CHR\$ (31)), and the command is executed when the terminator is received or the buffer becomes full.

Each command is checked for the correct format. If an error is detected, an error message is printed.

3. Precautions on Switching Modes

Each time the printer is switched from one mode to the other, a carriage return automatically takes place, followed by a line feed. After this occurs, all the printer settings other than COLOR* and FORMAT* are the same as those in effect immediately after it is turned on.

Reference: Initial settings at power-on

| | |
|---------------------------------|--|
| Coordinate origin: | The initial pen position is the new origin (0, 0). |
| ORG coordinate origin (Ox, Oy): | (0, 0) |
| Line type: | 0 (Solid line) |

| | |
|------------------|-----------------------------------|
| Line scale: | 6.4 mm |
| Alpha scale | 1 |
| Alpha rotate: | 0 (Normal position) |
| Character space: | 2 |
| Line spacing: | 6 |
| * FORMAT: | 0 (Reset) |
| * COLOR: | 0 (Black) |
| | *: not changed by mode switching. |

A color detection is performed immediately after power-on in order to move the black pen to the home position.

4. Commands

In addition to the ordinary printer output commands (LPRINT, LPRINT USING, LLIST), there are 11 plotting commands, 6 character symbol commands, 4 control commands, and 2 character control commands that can be used only in character mode.

The commands LPRINT and LPRINT USING, like the commands PRINT and PRINT USING, print the results of operations, etc. The LLIST command, like the LIST command, prints the contents of programs. These three commands can be used only in character mode. Plotter commands consist of a command part (one upper-case alphabetic character) and a parameter (parameters) defined by numeric data (some commands have no parameter).

Example:

```
LPRINT  CHR$(28) ; CHR$(37)
LPRINT  "D0,0,50,-30"
          |-----|
          Command  Parameter
```

Note that in the P command (PRINT), a character other than the function codes, CHR\$(1)–CHR\$(31), is used as a parameter.

Use a comma (,) to separate parameters (numeric data). To indicate the end of a command, use a function code other than CHR\$(0), such as LF (CHR\$(10)) and CR (CHR\$(13)).

A numeric parameter is generally a number with up to three digits to the left of the decimal point and up to one digit to the right of the decimal point. The fractional part must be a multiple of 0.2, which is the minimum increment of length (0.2 mm) or angle (0.2 degrees). Any smaller fractions are ignored. Thus, a numeric parameter can range from –999.8 to 999.8. Any blanks are ignored.

For any integer parameter, the fractional part ignored if one is present.

<Reference>

Unit of numeric parameters

Length unit: mm (-999.8 mm ~ 999.8 mm)

Angle unit: degree (-999.8° ~ 999.8°)

* Using commands in character mode

In character mode, all codes sent to the printer are directly dealt with as characters. Although plotter commands cannot be used as they are, a single command immediately following the ESC code (CHR\$(27)) can be executed to change character size, color, or horizontal and vertical coordinates.

Example:

```
10 LPRINT CHR$(28);CHR$(46)
20 LPRINT "CIRCLE"
30 LPRINT CHR$(27);
40 LPRINT "C40,-20,20"
50 END
```

CIRCLE

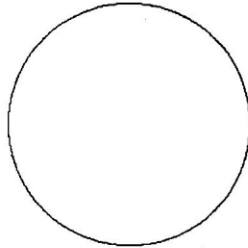

5. Coordinate Systems

Two coordinate systems are available with the plotter-printer; one is an absolute coordinate system and the other is an ORG relative coordinate system that can be specified by using an ORG command. An ORG coordinate system specifies its origin (0, 0) based on absolute coordinates.

This ORG coordinate system is initialized to the absolute coordinate system at power on. It is also reset to the absolute coordinate system any time the operation mode is switched or the HOME command is executed, or after pen replacement. The absolute coordinate origin is specified at the position where the pen is located after a power-on initialization, mode change, error, HOME or TEST command execution, or pen replacement. When the FEED key is pressed or a LINE FEED command is executed, the absolute coordinates on the paper varies by the paper movement. The following table summarizes the above discussions:

○ : Resetting Δ : Variation X : No change

| | Absolute coordinate system | ORG coordinate system |
|--|----------------------------|-----------------------|
| (1) Power on | ○ | ○ |
| (2) Mode switching (including re-specifying mode) | ○ | ○ |
| (3) When an error occurs | ○ | X |
| (4) When HOME command is executed. | ○ | ○ |
| (5) When TEST command is executed. | ○ | X |
| (6) After a pen has been replaced. | ○ | ○ |
| (7) When the FEED key is pressed or a LINE FEED command is executed. | Δ | X |
| (8) After a line feed in character mode. | Δ | X |

The absolute coordinates range from $(-6553.4, -6553.4)$ to $(6553.4, 6553.4)$. If a specified coordinates is within this range, but out of the paper width, the pen moves up to the edge of the paper toward the specified direction, then stay there without occurring an error until the drawing point comes back on the paper area.

The ORG coordinate origin can be specified at any absolute coordinates between $(-999.8, -999.8)$ and $(999.8, 999.8)$ by using an ORG command.

Actual plotting should be confined to an area of 96 mm (horizontal) by 200 mm (vertical) because the printer cannot feed the paper backward (in the +Y direction) more than 200 mm from the foremost drawing point.

Example:

Execute the following program to understand how large an area the printer can plot.

```

10 LPRINT CHR$(28);CHR$(37)
20 LPRINT "00,-200"
30 LPRINT "A0,0,96,200"
40 LPRINT "A0,10,50,-50"
50 LPRINT "A0,0,96,200"
60 END

```

Reference:

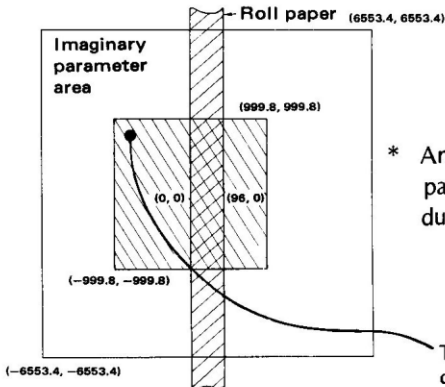

* An error occurs if this parameter area is exceeded during the command execution.

The ORG coordinate origin can be specified anywhere within this range.

6. Formats for Commands and Their Parameters

A plotter command is used by writing it in an LPRINT statement. Commands without any parameter are enclosed between quotation marks (").

Examples: LPRINT "H" in manual execution, or
100 LPRINT "H" in programs.

A parameter may be either a constant or a variable; the command formats are different:

Constant parameters. The command and its parameter or parameters are enclosed within quotation marks, separated by commas (,).

Examples: LPRINT "00,0"
LPRINT "D10,55,80,20"

Variable parameters. Place a semicolon (;) before each variables. If a comma is needed between the variables, place a semicolon and enclose a comma with quotation marks (; " , ").

Examples: LPRINT "A0,0,";X;" ";Y
LPRINT "C";I;" ";J;" ";R

Example:

```
10 LPRINT CHR$(28);CHR$(37)
20 LPRINT "050,-50"
30 FOR R=5 TO 30 STEP 5
40 LPRINT "C0,0,";R
50 NEXT R
```

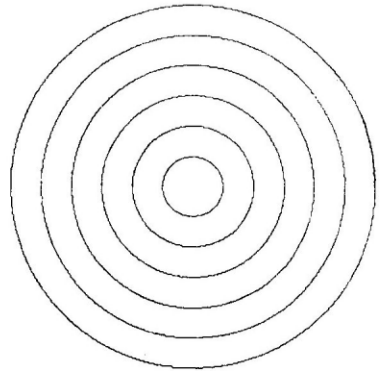

7. Commands Affected as a Result of Status Modification by Other Commands

| Status | Status setting command | Affected command |
|------------|---|--|
| Coordinate | ORIGIN (O) | DRAW (D)
MOVE (M)
QUADRANGLE (A)
CIRCLE (C)
AXIS (X) |
| Line | LINE TYPE (L)
LINE SCALE (B) | DRAW (D)
RELATIVE DRAW (R) |
| Character | ALPHA SCALE (S)
ALPHA ROTATE (Q)
SPACE (Z) *1
HORIZONTAL/VERTICAL
PRINT (Y) | PRINT (P) |
| Symbol | ALPHA SCALE (S)
ALPHA ROTATE (Q) | MARK (N) |
| Line feed | ALPHA SCALE (S)
SPACE (Z) *2
HORIZONTAL/VERTICAL
PRINT (Y) | LINE FEED (F) |

*1 Character spacing only. *2 Line spacing only.

8. Errors

The following four types of errors can be detected and the error messages are as indicated below.

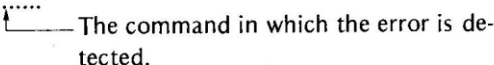
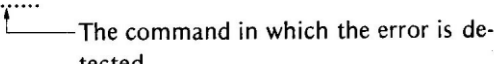
- (1) Command errors: C-ERR '.....'

- (2) Parameter errors: P-ERR '.....'

- (3) Mode errors: M-ERR
- (4) Overrun errors: O-ERR

When any of the above errors occurs, a CR and LF occur after the corresponding message is printed, and the new pen position becomes the new absolute coordinate origin.

Whenever an error occurs, the ERROR signal goes low in order to inform the computer of the error, except for mode and parameter errors caused by too many or too few parameters specified in a command.

*To release the ERROR signal, press the FEED key with the ON LINE/LOCAL switch at ON LINE.

COMMANDS

The following notation is used to explain the commands in this manual:

- (1) Block letters indicate words that must be written exactly as shown.
- (2) Brackets “[]” indicate that the parameter or parameters they enclose may be omitted.
- (3) Braces “{ }” indicate that one of the parameters they enclose must be specified.
- (4) An asterisk “*” indicates that the parameter or parameters preceding it may appear more than once.
- (5) The integer part of any parameter may have up to three digits. The range of a “real number” value is from -999.8 to 999.8.
- (6) Blanks are ignored in any command other than the PRINT statement.
- (7) The + and - signs are allowed in parameters; the + may be omitted.
- (8) The minimum increments are 0.2 mm for length and 0.2 degrees for angle.
- (9) (Term) represents a command terminator, which may be any code from CHR\$(1) to CHR\$(31). For example, CR(CHR\$(13)) and LF(CHR\$(10)) are allowable terminators.

ORIGIN

○ [absolute X coordinate, absolute Y coordinate] (Term)

Function: Specifies an origin of ORG coordinate system.

Parameters: The two parameters are real numbers with an integer part of three digits or less.

Explanation: This command specifies the point represented by the absolute coordinates (x, y) to be the new origin of ORG coordinate system which will apply to all subsequent graphic commands until another origin is specified.

If the coordinate parameters are not specified, the pen position at the time this command is executed becomes the new origin.

DRAW

D [starting X coordinate, starting Y coordinate]
[, X coordinate, Y coordinate] * (Term)

Function: Draws straight line segments between the successive ORG coordinates.

Parameters: The coordinate parameters are real numbers in ORG coordinates. Any number of parameter pairs may be specified within a logical line.

Explanation: This command draws straight lines between successive points in ORG coordinates. If the starting coordinates (x, y) are not specified, the first straight line begins from the current pen position. If the second coordinate parameters are the same as the starting coordinate parameters, or if there are no subsequent coordinate parameters specified, the pen only moves to the starting point and does not draw any line. At least one parameter pair must be specified.

Example:

```
10 LPRINT CHR$(28);CHR$(37)
20 LPRINT "050,-50"
30 LPRINT "00,10,0,-10"
40 LPRINT "0,20,-10"
50 LPRINT "00,0"
60 LPRINT "00,0,70,-50,70,0,0,0"
70 END
```

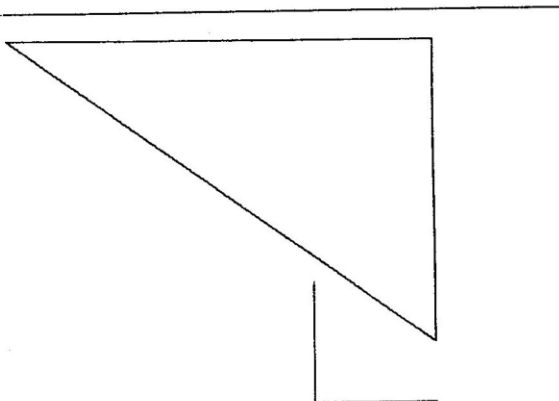

RELATIVE DRAW

I X direction displacement, Y direction displacement
[, X direction displacement, Y direction displacement]*
(Term)

Function: Draws straight lines connecting the points defined by the specified displacements.

Parameters: One or more pairs of the X and Y displacements which define the points to be connected. Any number of parameter pairs may be specified within a logical line.

Explanation: Draws lines to points given by the specified displacements in the X and Y directions from the current pen position.

Example:

```
10 LPRINT CHR$(28);CHR$(37)
20 LPRINT "10,0,20,10,20,-5,20,-10"
```

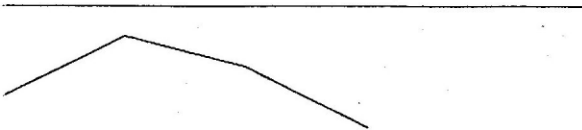

MOVE

M [X coordinate] , [Y coordinate] (Term)

Function: Moves the pen holder assembly with the pen up to the point defined by the specified ORG coordinates.

Parameters: An X and/or Y ORG coordinate. Either or both of the parameters are not specified, the coordinates are assumed to be 0.

Explanation: Moves the pen to the point defined by the specified ORG coordinates.

Example:

```
10 LPRINT CHR$(28);CHR$(37)
20 LPRINT "D-5,0,5,0"
30 LPRINT "D0,-5,0,5"
40 LPRINT "M20,-20"
50 LPRINT "N3"
```

T

*

*See page 39 for the description of "N3".

RELATIVE MOVE

R X direction displacement, Y direction displacement (Term)

Function: Moves the pen holder assembly with the pen up to the point defined by the specified X- and Y- direction displacements.

Parameters: An X and/or Y displacement.

Explanation: Moves the pen holder assembly with the pen up by the specified X and Y displacements from the current pen position.

Example:

```
10 LPRINT CHR$(28); CHR$(37)
20 FOR I=1 TO 5
30 LPRINT "R10,0"
40 LPRINT "N3"
50 NEXT I
```

* * * * *

QUADRANGLE

A starting X coordinate, starting Y coordinate,
diagonal X coordinate, diagonal Y coordinate (Term)

Function: Draws a quadrangle whose two diagonal points are defined by the two specified pairs of X and Y coordinates and whose sides are parallel to the X and Y axes.

Parameters: All the parameters are ORG coordinates and cannot be omitted.

Explanation: Draws a quadrangle that has the two diagonal points specified by the corresponding pairs of parameters and sides parallel to the X and Y axes. The pen moves from and returns to the starting point.

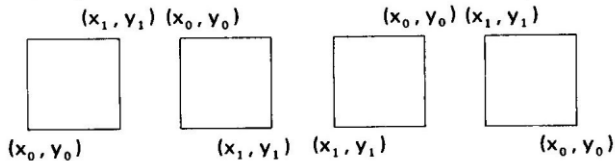

Example:

```
10 LPRINT CHR$(28);CHR$(37)
20 LPRINT "050,-25"
30 FOR I=30 TO 5 STEP -5
40 LPRINT "A";-I;";";I;";";I;";";-I
50 NEXT I
```

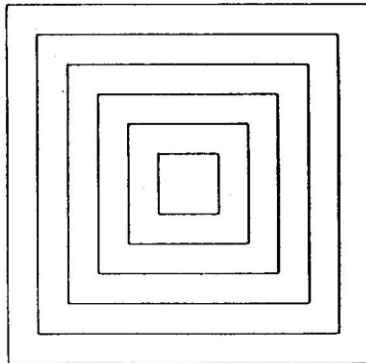

CIRCLE

C [X center coordinate, Y center coordinate],
radius [, initial arc angle, final arc angle] (Term)

Function: Draws a circle or circular arc that has the center defined by the specified X and Y ORG coordinates, and the specified radius.

Parameters: The X and Y center coordinates may be omitted. If they are omitted, the current pen position is used as the center.
The radius parameter is a real number greater than or equal to 0.4 and cannot be omitted.
The initial and final arc angle parameters are required to draw a circular arc. They must be omitted when drawing a full circle. The angles are measured as follows:

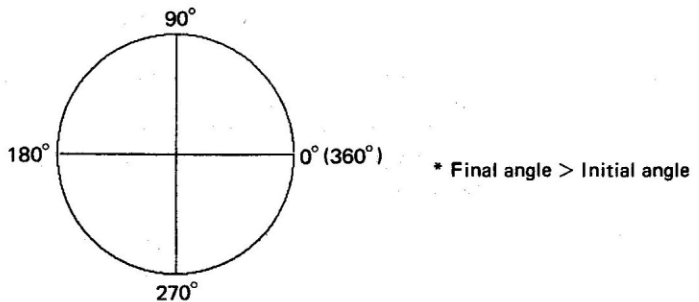

Explanation: Draws a circle with the specified radius around the center defined by the specified X and Y ORG coordinates. If an initial and final arc angle are specified, this command draws a circular arc that covers the sector defined by the two angles.

Example:

```
10 LPRINT CHR$(28);CHR$(37)
20 LPRINT "C30,-30,10"
30 LPRINT "C,20"
40 LPRINT "C30,-30,30,90,270"
50 LPRINT "I0,60"
```

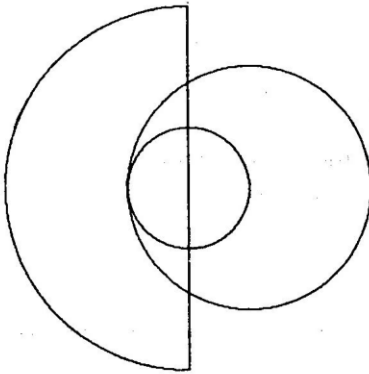

AXIS

X axis direction, size of scale division, number of scale divisions
(Term)

Function: Draws a coordinate axis in the specified direction (+Y, +X, -Y, or -X) from the current origin of ORG coordinate system.

Parameters: The axis direction parameter is a real number which is equal to either 0, 1, 2 or 3. It is evaluated as an integer and represents an axis direction as follows:

0: +Y, 1: +X, 2: -Y, 3: -X

The scale division parameter is a real number and is evaluated as an integer.

The number of scale divisions parameter is a real number and is evaluated as an integer.

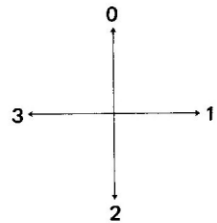

Explanation: Draws a coordinate axis in the specified direction with the specified number of scale divisions.

Example:

```

10 LPRINT CHR$(28);CHR$(37)
20 LPRINT "048,-50"
30 FOR I=0 TO 3
40 LPRINT "X":I: ",5,8"
50 NEXT I
    
```

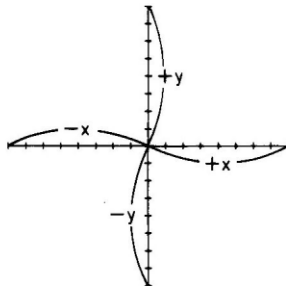

GRID

G direction of stripes, range in X axis direction,
range in Y axis direction [, stripe separation] (Term)

Function: Draws horizontal or vertical stripes enclosed within a rectangle, beginning from the current pen position, whose sides are parallel to the X and Y axes.

Parameters: The stripe direction parameter is a real number equal to 0, 1 or 2. It is evaluated as an integer and represents a stripe direction as follows:

0: No stripes are drawn.

1: Horizontal stripes

2: Vertical stripes

Ranges in the X- and Y-axis directions are specified with real numbers.

The stripe separation parameter is a positive real number. 1 is assumed if this parameter is omitted. If 0.2 or less is specified, the effect is the same as 0.2, and the entire rectangle area is covered.

Explanation: Draws stripes within the specified rectangle. The pen returns to the starting point when the stripe has been drawn. This command can be used to draw lines or a grid within a rectangle.

Example:

```
10 LPRINT CHR$(28);CHR$(37)
20 LPRINT "00,0"
30 FOR I=0 TO 2
40 LPRINT "A";I*30;"",-20,";I*30+20;"
   0"
50 LPRINT "G";I;"",20,20,2"
60 NEXT I
```

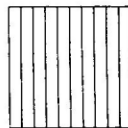
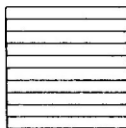

LINE TYPE

L line type (Term)

Function: Specifies the type of line to be drawn by a DRAW (D) or RELATIVE DRAW (R) command.

Parameter: A real number equal to 0, 1, 2 or 3. It is evaluated as an integer and specifies a line type as follows:

- 0: Solid line
- 1: Broken line
- 2: One-dot chained line
- 3: Two-dot chained line

Explanation: This command defines the type of line to be drawn by a DRAW or RELATIVE DRAW. Turning the printer on initializes the line type parameter to 0 (solid line).

Example:

```
10 LPRINT CHR$(28);CHR$(37)
20 FOR I=0 TO 3
30 LPRINT "L";I
40 LPRINT "H10"
50 LPRINT "D0,0,96,0"
60 NEXT I
```

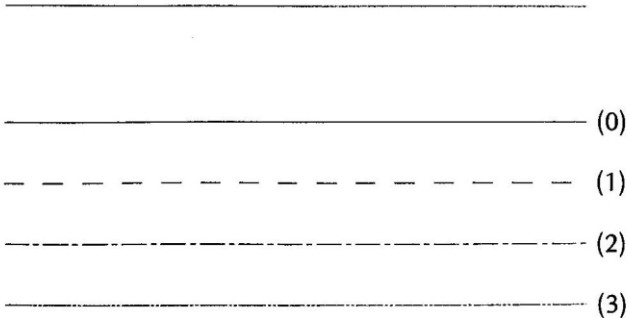

LINE SCALE

B pitch of broken line, etc. (Term)

Function: Specifies the pitch of a broken line, one-dot chained line and a two-dot chained line.

Parameter: A real number greater than or equal to 0 and less than 1000.

Explanation: This command is used in combination with a LINE TYPE (L) command to specify a pitch. Recommended values are 0.4 or larger for broken lines, 3.2 or larger for one-dot chained lines, and 6.4 or larger for two-dot chained lines.

Example:

```
10 LPRINT CHR$(28);CHR$(37)
20 FOR I=1 TO 4
30 B=1.6*I
40 LPRINT "H5"
50 LPRINT "P *B=";B
60 LPRINT "H2"
70 LPRINT "B";B
80 FOR L=0 TO 3
90 LPRINT "L";L
100 LPRINT "D0,0,96,0"
110 LPRINT "H2"
120 NEXT L
130 NEXT I
```

*B= 1.6

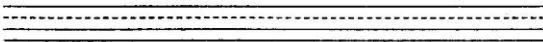

*B= 3.2

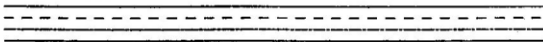

*B= 4.8

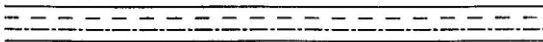

*B= 6.4

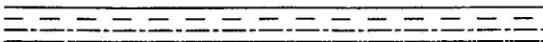

ALPHA SCALE

S scale of character (Term)

Function: Specifies the size of characters and symbols to be printed.

Parameter: The character scale parameter is a real number greater than or equal to 0 and less than 10. It is evaluated as an integer.

Explanation: This command defines the size of characters and symbols written by a PRINT (P) or MARK (N) statement, or the size of characters printed in the character mode. 0 defines the minimum size, 1 doubles the minimum size, 3 triples it, and so on. The following diagram gives the dimensions for scale size 0.

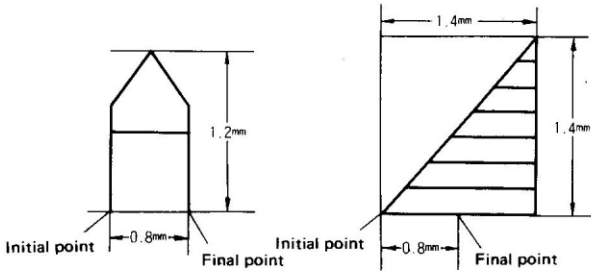

Normal character

Special character (CHR\$ (128) ~ CHR\$ (159),
CHR\$ (224) ~ CHR\$ (254))

Before a special character is written, either a "Z3, 1" (establishes the lateral writing mode) or "Z0, 3" (establishes the longitudinal writing mode) command must be issued with the SPACE statement, to be described later.

Example:

```
10 LPRINT CHR$(28);CHR$(37)
20 FOR I=0 TO 9
30 LPRINT "S"; I
40 LPRINT "PA"
50 NEXT I
```



ALPHA ROTATE

Q rotational angle (Term)

Function: Specifies the rotational angle (orientation) of character strings to be printed.

Parameter: A real number equal to 0, 1, 2 or 3. It is evaluated as an integer.

Explanation: The parameter specifies the rotational angle of character strings as follows:

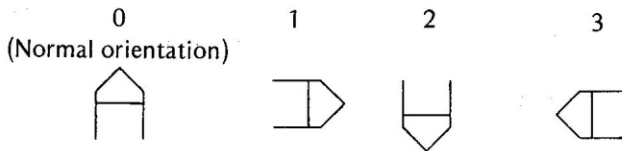

Example:

```
10 LPRINT CHR$(28);CHR$(37)
20 LPRINT "M20,0"
30 FOR I=0 TO 3
40 LPRINT "Q"; I
50 LPRINT "PABC"
60 NEXT I
```

ABC
ABC
ABC

SPACE

Z spacing between current and next characters
[, spacing between current and next lines] (Term)

- Function:** Specifies a spacing between the current character and the next character to be printed, and/or a spacing between the current line and the next line to be printed.
- Parameters:** Both the character and line spacing parameters are real numbers greater than or equal to 0 and less than 16 and evaluated as integers. The line spacing parameter may be omitted.
- Explanation:** This command specifies a character spacing and/or line spacing. The spacing values are initialized to "Z2,6" when the power is turned on.

Character and line spacing at Z2,6:

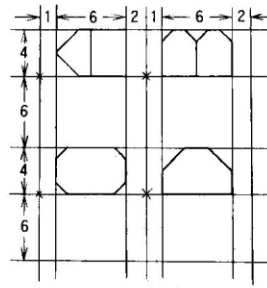
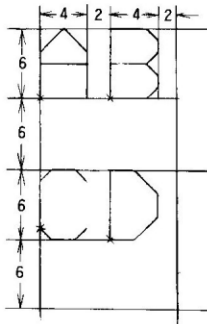

The "X" mark indicates the starting point.

It should be noted that there is some difference in the spacing between normal (horizontal) and vertical printing. For special characters (CHR\$(128) ~ CHR\$(159), and CHR\$(224) ~ CHR\$(240)), "Z3,1" is recommended for normal printing, and "Z0,3" for vertical printing. When the line spacing parameter is omitted, the previous specification (or initial setting) remains in effect.

The line spacing setting also applies to paper feeding in subsequent LINE FEED commands.

Example:

```
10 LPRINT CHR$(28);CHR$(46)
20 FOR I=0 TO 16 STEP 8
30 LPRINT CHR$(27);"Z";I;" ";I
40 LPRINT "SPACE"
50 LPRINT "SPACE"
60 LPRINT "SPACE"
70 LPRINT CHR$(27);"F1"
80 NEXT I
```

SPACE
SPACE
SPACE

S P A C E
S P A C E
S P A C E

S P A C E

S P A C E

S P A C E

HORIZONTAL/VERTICAL PRINT

Y horizontal/vertical selection (Term)

Function: Specifies whether the subsequent character strings are to be printed horizontally or vertically.

Parameter: A real number equal to or greater than 0 and less than 2. It is evaluated as an integer. It selects horizontal or vertical writing as follows:

0: Horizontal

1: Vertical

Explanation: When vertical printing is selected, the characters are printed in the orientation defined by the command ALPHA ROTATE (Q) 3, and lowercase characters, punctuation marks, brackets, etc. are also handled vertically.

Example:

```
10 LPRINT CHR$(28);CHR$(46)
20 LPRINT "ABCDEFGHI JKLMN"
30 LPRINT CHR$(27);"Y1"
40 LPRINT "ABCDEFGHI JKLMN"
```

```
ABCDEFGHI JKLMN
C B U O W L S I H T Y J Z
```

PRINT

P character string (Term)

Function: Prints the specified character string or other data.

Parameter: A string of characters or codes other than function codes; codes from CHR\$(32) to CHR\$(255) are allowed.

Explanation: This command is used only in the graphic mode. It converts character strings, data or codes following the P command to characters to be printed. (Codes CHR\$(127) and CHR\$(255) are undefined, and ignored.)

The command is provided to allow printing of characters and various data which cannot be directly printed in the graphic mode.

The size, orientation, character and line spacing, and horizontal or vertical printing selection are respectively defined by the previous ALPHA SCALE (S), ALPHA ROTATE (Q), SPACE (Z), and HORIZONTAL/VERTICAL PRINT (Y).

Since no automatic line feed takes place when this command is used, a LINE FEED command (F) must be used when a carriage return and line feed is required.

Example:

```
10 LPRINT CHR$(28);CHR$(37)
20 LPRINT "P **FA-10 PLOTTER I/O**"
```

FA-10 PLOTTER I/O

MARK

N type of mark (Term)

Function: Prints the specified mark centered at the current pen position.

Parameter: A real number greater than or equal to 0 and less than 10. It is evaluated as an integer and selects one of the following ten marks:

0: No printing 1: + 2: X 3: * 4: □
5: ◊ 6: ⊙ 7: △ 8: ⊗ 9: ⊞

Explanation: This command prints the one selected from among the above ten marks, centered at the current pen position, and then returns the pen to the original position. The pen must be moved when another character, symbol or mark is to be printed next.

The size and orientation of the mark are defined by the ALPHA SCALE (S) and ALPHA ROTATE (Q) commands which are presently effective. These marks are useful in drawing line graphs.

Example:

```
10 LPRINT CHR$(28);CHR$(37)
20 FOR I=0 TO 9
30 LPRINT "M";6+I*9;"",-10"
40 LPRINT "N";I
50 NEXT I
```

+ X * □ ◊ ⊙ △ ⊗ ⊞

NEW PEN

J pen color (Term)

Function: Selects a pen color.

Parameter: A real number equal to 0, 1, 2 or 3. It is evaluated as an integer and selects one of the following four colors:

0: Black 1: Blue 2: Green 3: Red

Explanation: The numbers are assigned to the pens on the holder assembly clockwise as viewed from the rear; the one that comes to the top at power on is regarded as 0. The pen colors are normally arranged as shown above.

Example:

```
10 LPRINT CHR$(28);CHR$(37)
20 FOR I=0 TO 3
30 LPRINT "H10"
40 LPRINT "J"; I
50 LPRINT "PABCD"
60 NEXT I
```

ABCD Black

ABCD Blue

ABCD Green

ABCD Red

LINE FEED

F number of lines (Term)

Function: Feeds the paper by the specified number of lines.

Parameter: A real number which is 3 digits or less. It is evaluated as an integer.

Explanation: The line spacing applied to forward or backward line feeding by this command is defined by the SPACE (Z), ALPHA SCALE (S), and HORIZONTAL/VERTICAL PRINT (Y) commands.

When the parameter is positive, the paper is fed forward. When negative, the paper is fed backward. However, the paper cannot be physically moved backward beyond 200 mm from the foremost point that the pen has reached.

It should be noted that, after this command is executed, the absolute coordinate system is displaced by the specified amount.

Example:

```
10 LPRINT CHR$(28);CHR$(37)
20 FOR I=-2 TO 2
30 LPRINT "PL/F"; I
40 LPRINT "F"; I
50 NEXT I
```

L/F 0L/F 1
L/F-1 L/F 2

L/F-2

HOME

H [distance from foremost drawing-point] (Term)

Function: Used to move the pen from the plotted area for operator inspection, or to redefine the home position (origin of absolute coordinate system.)

Parameter: A positive real number or 0; may be omitted.

Explanation: If the parameter is specified, the paper is fed the specified distance from the current foremost drawing point, and then the pen is moved to the left end.

This pen position becomes the new origin of absolute coordinate system.

When the parameter is omitted, the paper is fed to the current foremost drawing point and the pen is returned to the left end. The absolute coordinate system is not changed and can be used for subsequent printing.

Example:

```
10 LPRINT CHR$(28);CHR$(37)
20 LPRINT "030,-20"
30 LPRINT "C0,0,10"
40 LPRINT "H"
50 LPRINT "C10,0,10"
60 LPRINT "H5"
70 LPRINT "030,-20"
80 LPRINT "C0,0,10"
```

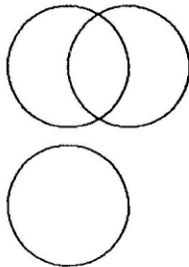

TEST

@ (CHR\$(64)) (Term)

Function: Provides means of checking the pens for proper inking and correct color arrangement, and of trial printing.

Parameter: No parameter is used.

Explanation: The pen tips may dry and fail to properly print if the pens are left uncapped for a long period of time, because they use water-color ink. When this occurs, the TEST command can be used to check the pens. The command is also useful for trial printing or to check on color arrangement.

Example:

```
10 LPRINT CHR$(28);CHR$(37)
20 LPRINT CHR$(64)
```

Black Blue Green Red

TAB

T number of positions (Term)

Function: Moves the pen to the right from the left end by the specified number of print positions.

Parameter: A real number which is 3 digits or less. It is evaluated as an integer.

Explanation: This command is effective only in the character mode and tabulates from the left end by the specified number of print positions. If the parameter value exceeds the number of print positions comprising one line, the pen is moved to the beginning of the next line.

Example:

```
10 LPRINT CHR$(28);CHR$(46)
20 FOR I=1 TO 4
30 LPRINT "1234567890";
40 NEXT I
50 LPRINT CHR$(10);CHR$(27);
60 LPRINT "T10"
70 LPRINT "TAB 10"
```

1234567890123456789012345678901234567890
TAB 10

FORMAT

$$? \left\{ \begin{array}{c} 0 \\ 1 \end{array} \right\} \text{ (Term)}$$

Function: Provides a 6-position blank area at the left end after each automatic line feed other than CR (Carriage Return) or LF (Line Feed).

Parameter: 0 or 1. 1 puts this line formatting function in effect, and 0 terminates the function.

Explanation: This command is useful to align the beginnings of program listing lines.
The LLIST command that provides a program listing can be used only in the character mode.

Example 1:

```
***** FORMAT COMMAND RESET *****  
  
10 LPRINT CHR$(28);CHR$(46),CHR$(27);  
20 LPRINT "?0"  
30 LPRINT "***** FORMAT COMMAND R  
ESET *****"  
40 LPRINT CHR$(10)  
50 LLIST
```

Example 2:

```
***** FORMAT COMMAND SET *****  
  
10 LPRINT CHR$(28);CHR$(46),CHR$(27);  
20 LPRINT "?1"  
30 LPRINT "***** FORMAT COMMAND  
SET *****"  
40 LPRINT CHR$(10)  
50 LLIST
```

PROGRAMMING EXAMPLES

The following programs produce simple graphic patterns.

***** No. 1 *****

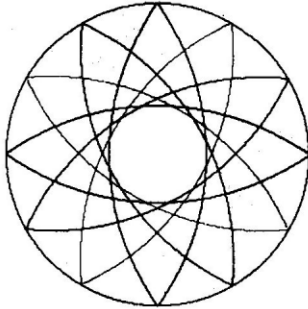

```
10 REM ***** No. 1 *****
20 LPRINT CHR$(28);CHR$(37)
30 LPRINT "H10"
40 LPRINT "J0":LPRINT "S2"
50 LPRINT "P ***** No. 1 *****
   **"
60 LPRINT "H10"
70 J=1
80 FOR I=0 TO 330 STEP 30
90 X=35*COS(I)+48
100 Y=35*SIN(I)-40
110 LPRINT "J":J
120 LPRINT "C";X;";";Y;";43;";144.4+I;
   ";";215.6+I
130 J=J+1
140 IF J=4 THEN J=1
150 NEXT I
160 LPRINT "J0"
170 LPRINT "C48,-40,25"
180 LPRINT "H20"
```

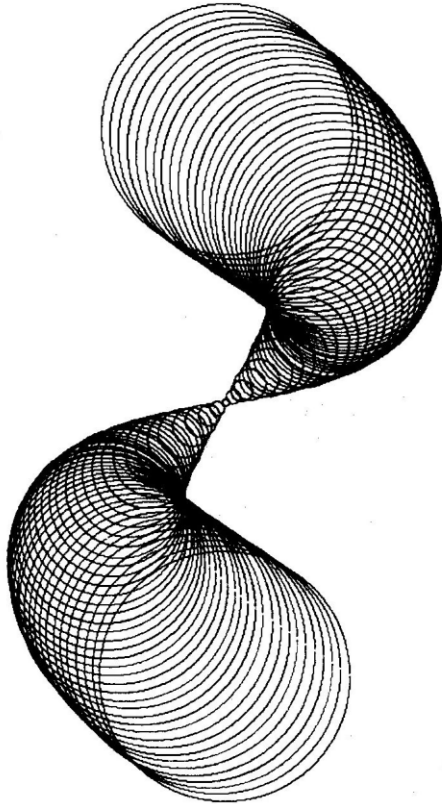

```
10 REM ***** No. 2 *****
20 LPRINT CHR$(28);CHR$(37)
30 LPRINT "H10"
40 LPRINT "J0":LPRINT "S2"
50 LPRINT "P ***** No. 2 *****
   **"
60 LPRINT "H30"
70 Y=0: J=2
80 FOR I=0 TO 360 STEP 4
90 LPRINT "J"; J
100 X=20*SIN(I)+48
110 Y=Y-1.0
120 R=ABS(20*COS(I/2))+0.6
130 LPRINT "C";X;";";Y;";";R
140 J=J+1
150 IF J=4 THEN J=0
160 NEXT I
170 LPRINT "H20"
```

*** SIN, COS, TAN<DEG> ***

| X | SIN(X) | COS(X) | TAN(X) |
|----|---------|---------|---------|
| 0 | 0 | 1 | 0 |
| 1 | 0.01745 | 0.99985 | 0.01746 |
| 2 | 0.0349 | 0.99939 | 0.03492 |
| 3 | 0.05234 | 0.99863 | 0.05241 |
| 4 | 0.06976 | 0.99756 | 0.06993 |
| 5 | 0.08716 | 0.99619 | 0.08749 |
| 6 | 0.10453 | 0.99452 | 0.1051 |
| 7 | 0.12187 | 0.99255 | 0.12278 |
| 8 | 0.13917 | 0.99027 | 0.14054 |
| 9 | 0.15643 | 0.98769 | 0.15838 |
| 10 | 0.17365 | 0.98481 | 0.17633 |
| 11 | 0.19081 | 0.98163 | 0.19438 |
| 12 | 0.20791 | 0.97815 | 0.21256 |
| 13 | 0.22495 | 0.97437 | 0.23087 |
| 14 | 0.24192 | 0.9703 | 0.24933 |
| 15 | 0.25882 | 0.96593 | 0.26795 |
| 16 | 0.27564 | 0.96126 | 0.28675 |
| 17 | 0.29237 | 0.9563 | 0.30573 |
| 18 | 0.30902 | 0.95106 | 0.32492 |
| 19 | 0.32557 | 0.94552 | 0.34433 |
| 20 | 0.34202 | 0.93969 | 0.36397 |
| 21 | 0.35837 | 0.93358 | 0.38386 |
| 22 | 0.37461 | 0.92718 | 0.40403 |
| 23 | 0.39073 | 0.9205 | 0.42447 |
| 24 | 0.40674 | 0.91355 | 0.44523 |
| 25 | 0.42262 | 0.90631 | 0.46631 |
| 26 | 0.43837 | 0.89879 | 0.48773 |
| 27 | 0.45399 | 0.89101 | 0.50953 |
| 28 | 0.46947 | 0.88295 | 0.53171 |
| 29 | 0.48481 | 0.87462 | 0.55431 |

This program generates a trigonometric function table for angles from 0 to 29 degrees in increments of 1 degree. The function values are calculated down to the fifth digit after the decimal point.

First, lines 100 to 140 draws the table frame and then the subsequent statements print the values properly placed within the appropriate boxes.

The function values are rounded to the fifth digit to the right of the decimal point in line 220 and then the results are printed in lines 230 to 260.

The angle is increased by one degree in this example. It may also be a good exercise to vary the increment or change the unit of angles.

```

10 REM ***** No.3 *****
20 LPRINT CHR$(28);CHR$(37)
30 ANGLE 0
40 LPRINT "J0"
50 LPRINT "H10":J=1
60 LPRINT "S2"
70 LPRINT "P *** SIN,COS,TAN<DEG> **
*"
80 LPRINT "H10"
90 LPRINT "S0"
100 LPRINT "D8,3,98,3":LPRINT "D8,-2,9
8,-2"
110 FOR I=1 TO 6:LPRINT "D8,";-I*12.4-
2;"",98;"",;-I*12.4-2:NEXT I
120 LPRINT "D8,3,8,-76.4"
130 LPRINT "D23,3,23,-76.4":LPRINT "D4
8,3,48,-76.4"
140 LPRINT "D73,3,73,-76.4":LPRINT "D9
8,3,98,-76.4"
150 LPRINT "J1"
160 LPRINT "M15,0":LPRINT "PX"
170 LPRINT "M30,0":LPRINT "PSIN(X)"
180 LPRINT "M55,0":LPRINT "PCOS(X)"
190 LPRINT "M80,0":LPRINT "PTAN(X)"
200 FOR I=0 TO 29
210 IF (I MOD 5)=0 THEN LPRINT "F1"
220 S=ROUND(SIN(I),-6):C=ROUND(COS(I),
-6):T=ROUND(TAN(I),-6)
230 LPRINT "M14,";-J*2:LPRINT "P";I
240 LPRINT "M30,";-J*2:LPRINT "P";S
250 LPRINT "M55,";-J*2:LPRINT "P";C
260 LPRINT "M80,";-J*2:LPRINT "P";T
270 J=J+1
280 NEXT I
290 LPRINT "H20"
300 LPRINT "J0"

```

***** Pie Chart *****

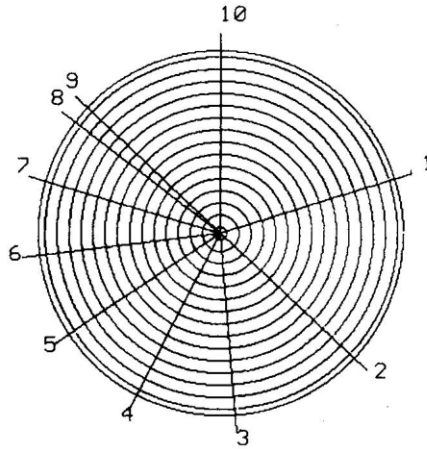

| | | | |
|--------|----------------|---------|--------|
| < 1 > | : TOKYO | 1265. k | 20.02% |
| < 2 > | : NEW YORK | 1065. k | 16.85% |
| < 3 > | : CHICAGO | 742. k | 11.74% |
| < 4 > | : LONDON | 568. k | 8.99% |
| < 5 > | : PARIS | 498. k | 7.88% |
| < 6 > | : SINGAPORE | 467. k | 7.39% |
| < 7 > | : SYDNEY | 421. k | 6.66% |
| < 8 > | : BUENOS AIRES | 361. k | 5.71% |
| < 9 > | : CAIRO | 108. k | 1.71% |
| < 10 > | : OTHERS | 824. k | 13.04% |
| | TOTAL | 6319. k | |

Explanation:

This program draws a simple pie chart.

Lines 30 to 130 are the data entry section and read data from DATA statements. If data entry is desired from the keyboard, change the READ statements to INPUT statements.

Lines 200 to 290 sort the input data. The data are converted to percentages of the total and are arranged in descending order.

The output to the printer begins from line 400; line 450 draws a circle. Then the circle is divided according to the values obtained by the change of coordinates in lines 520 to 550. Lines 590 to 620 draw smaller concentric circles (hatching) which may be omitted if no hatching is required. Lines 660 and 670 initialize the printer; the pen holder assembly is moved to the foremost line of the diagram, the black pen is brought to the top, and the printer is put in the character mode.

Lines 690 and after print character and numeric data. The numbers, names, quantities, and percentages are printed, and the total is finally printed.

Lines 900 and 910 are DATA statements which are required for the preceding READ statements.

```
10 REM ***** No. 4 *****
20 ANGLE 0
30 READ N
40 DIM D(N,2),D$(N)
50 TA=0
60 FOR I=1 TO N
70 READ D(I,1)
80 TA=TA+D(I,1)
90 NEXT I
100 FOR I=1 TO N
110 READ D$(I)
120 D(I,2)=D(I,1)/TA*100
130 NEXT I
200 REM *** SORT ***
210 FOR I=1 TO N-1
220 MA=-9E99
230 FOR J=I TO N-1
240 IF D(J,2)>MA THEN MA=D(J,2):M=J
250 NEXT J
260 S=D(I,1):D(I,1)=D(M,1):D(M,1)=S
270 S=D(I,2):D(I,2)=D(M,2):D(M,2)=S
280 T1$=D$(I):D$(I)=D$(M):D$(M)=T1$
290 NEXT I
```

```

400 REM *** PLOTTER ***
410 LPRINT CHR$(28);CHR$(37)
420 LPRINT "S2":LPRINT "J0":LPRINT "P
      ***** Pie Chart *****"
430 LPRINT "S1"
440 LPRINT "O46,-50"
450 LPRINT "C0,0,30"
460 LPRINT "M0,0"
470 LPRINT "D0,0,0,30"
480 RT=0:RS=90:C=1
490 FOR I=1 TO N
500 R=D(I,2)*360/100
510 RT=RT+R
520 X=ROUND(33*COS(90-RT),-3)
530 Y=ROUND(33*SIN(90-RT),-3)
540 X1=ROUND(35*COS(90-RT),-3)
550 Y1=ROUND(35*SIN(90-RT),-3)
560 LPRINT "J0"
570 LPRINT "D0,0,";X;",";Y
580 LPRINT "M";X1;",";Y1:LPRINT "P";MI
      D$(STR$(I),2)
590 LPRINT "J";C
600 FOR J=1 TO 30 STEP 2
610 LPRINT "C0,0,";30-J;",";90-RT;",";
      RS
620 NEXT J
630 RS=90-RT
640 C=C+1:IF C>3 THEN C=1
650 NEXT I
660 LPRINT "S1":LPRINT "J0"
670 LPRINT "H"
680 LPRINT CHR$(28),CHR$(46)
690 FOR I=1 TO N
700 LPRINT "<";USING"###";I;"> : ";
710 LPRINT D$(I);TAB(21);
720 LPRINT USING"#####";D(I,1);". k";
730 LPRINT "      ";USING"###.##";D(I,2)
      :CHR$(37)
740 NEXT I
750 LPRINT TAB(8);"TOTAL";TAB(15);
760 LPRINT USING"#####";TA;". k"
770 END
900 DATA 10,568,467,108,1265,421,361,1
      065,498,742,824
910 DATA LONDON,SINGAPORE,CAIRO,TOKYO,
      SYDNEY
920 DATA BUENOS AIRES,NEW YORK,PARIIS,C
      HICAGO,OTHERS

```

***** HOME *****

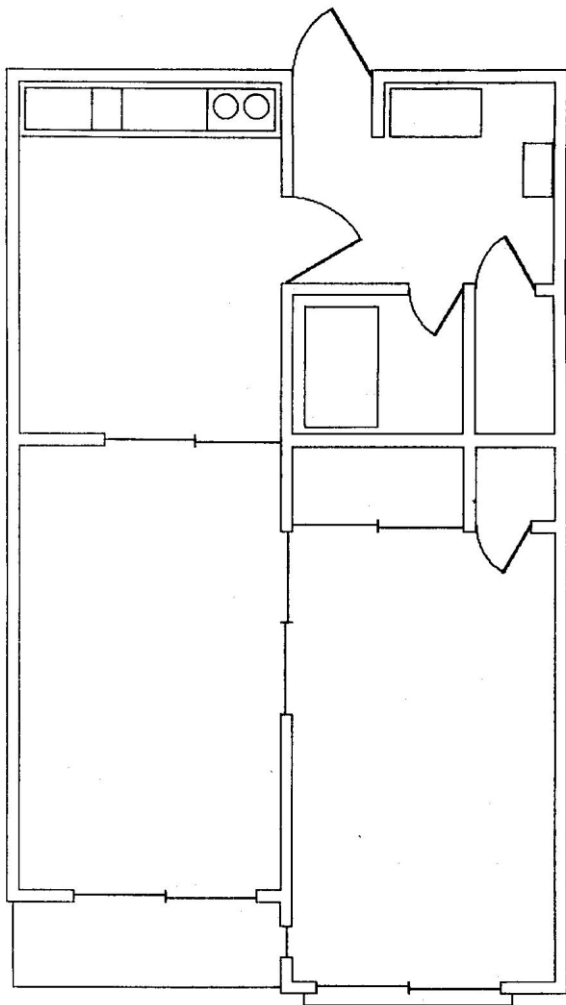

This program draws the house plans. This drawing example contains only the outside and inside walls, doors, and windows. The DATA statements starting from line 5000 are central to the program which define the positions of the respective areas and components. Lines are drawn by program sections written as subroutines. The subroutine beginning from line 1000 draws walls by RELATIVE DRAW command (I). The subroutine beginning from line 1100 is written independently of the above subroutine and draws the sliding doors, all of which are of the same type and size. The subroutine beginning from line 1200 draws the doors and also draws the arcs indicating their swing areas by using CIRCLE command (C).

It would be a useful exercise to draw detailed layout planning of household furniture, etc.

```

10 REM ***** No.5 *****
20 LPRINT CHR$(28);CHR$(37)
30 LPRINT "00,-10"
40 LPRINT "J0"
50 LPRINT "S2"
60 LPRINT "P ***** HOME *****
**"
70 LPRINT "S1":LPRINT "F2"
100 RESTORE 5010
110 GOSUB 1000
120 LPRINT "J1"
130 RESTORE 5090
140 GOSUB 1100
150 LPRINT "J2"
160 FOR I=1 TO 5
170 GOSUB 1200
180 NEXT I
190 LPRINT "J3"
200 LPRINT "02,-11,45,-11"
210 LPRINT "A3,-3,19,-10"
220 LPRINT "A14,-3,44,-10"
230 LPRINT "A33,-3,44,-10"
240 LPRINT "C36,-6,2"
250 LPRINT "C41,-6,2"
260 LPRINT "A63,-3,78,-11"
270 LPRINT "A85,-12,89.8,-21"
280 LPRINT "A49,-39,61,-59"
290 LPRINT "J0"
300 LPRINT "H"
310 END
1000 REM *** RELATIVE DRAW ***
1010 READ XX$
1020 IF XX$="*" THEN READ X,Y:LPRINT "M
":X:",":Y:GOTO 1010
1030 IF XX$="E" THEN RETURN
1040 X=VAL(XX$):READ Y
1050 LPRINT "I":X:",":Y
1060 GOTO 1010
1100 REM *** DRAW ***
1110 READ XX$
1120 IF XX$="E" THEN RETURN
1130 X=VAL(XX$):READ Y,X1,Y1
1140 LPRINT "D":X:",":Y:",":X1:",":Y1
1150 GOTO 1110
1200 REM *** DOOR ***
1210 READ X,Y,X1,Y1
1220 LPRINT "D":X:",":Y:",":X1:",":Y1:"
":X1-0.2:",":Y
1230 READ R,S,E
1240 LPRINT "C":X:",":Y:",":R:",":S:",":
:E
1250 RETURN
5000 REM *** DATA ***
5010 DATA *,0,0,47,0,0,-21,-2,0,0,19,-4
3,0,0,-58
5020 DATA 14,0,0,-2,-14,0,0,-73,9,0,0,-
2,-11,0,0,137
5030 DATA *,60,0,32,0,0,-152,-11,0,0,2,
9,0,0,74,-4,0,0,2,4,0,0,12,-13,0,0
,-14
5040 DATA -2,0,0,14,-28,0,0,-14,-2,0,0,
41,21,0,0,-2,-19,0,0,-23,28,0,0,25
5050 DATA 2,0,0,-25,13,0,0,23,-3,0,0,2,
3,0,0,33,-28,0,0,-9,-2,0,0,11
5060 DATA *,45,-106,0,-29,-4,0,0,-2,4,0
,0,-4,2,0,0,35,-2,0
5070 DATA *,45,-146,0,-6,6,0,0,2,-4,0,0
,4,-2,0
5080 DATA *,1,-137,0,-14,44,0,*,49,-152
,0,-2,34,0,0,2,E
5090 DATA 16,-60,8,31,-60,8,31,-60,31,-
62,31,-61,2,45,-61,2
5100 DATA 47,-74,8,61,-74,8,61,-74,61,-
76,61,-75,2,75,-75,2
5110 DATA 46,2,-76,46,2,-91,47,-91,45,-
91,45,8,-91,45,8,-106
5120 DATA 11,-135,8,26,-135,8,26,-135,2
6,-137,26,-136,2,41,-136,2
5130 DATA 51,-150,8,66,-150,8,66,-150,6
6,-152,66,-151,2,81,-151,2
5140 DATA 46,-141,46,-146,E
5150 DATA 60,-1,53,5,10,2,13,120,180,87
,-36,82,-27,4,10,120,180,46,-35,58
,-28
5160 DATA 14,30,90,75,-36,70,5,-43,8,9,
180,240,86,-75,81,5,-82,8,9,180,24
0

```

HOW TO USE THE CASSETTE INTERFACE

The cassette interface of this plotter-printer has the following functions:

- (1) Stores data on cassette tape.
 - 1) Writes programs on tape (SAVE, SAVE ALL).
 - 2) Reads programs from tape (LOAD, LOAD ALL).
 - 3) Writes the contents of data in memory on tape (PUT).
 - 4) Reads the contents of data in memory from tape (GET).
 - 5) Reads a program from tape and starts it from the beginning (CHAIN).
- (2) Communicates between two FA-10s
 - 1) Sends a program (SAVE ALL).
 - 2) Receives a program (LOAD ALL).
 - 3) Sends the contents of data in memory (PUT).
 - 4) Receives the contents of data in memory (GET).

Tape Recorders Connectable to Plotter-Printer

■ Types of tape recorders

Microcassette tape recorder CM-1, which is exclusively used for the FA-10, and other tape recorders using cassette tape or microcassette tape.

■ Requirements for connection

- 1) The MIC or similar input terminal of the recorder has an input impedance of $10\text{k}\Omega$ or more and a minimum input level of 3 mV or more.
- 2) The EAR or MONITOR terminal or similar output terminal of the recorder has an output impedance of 10Ω or less and an output level of 2.5 V or more.
- 3) The ratings of the REMOTE or similar terminal of the recorder are 24V DC, 1A or less.
- 4) Overall distortion should not exceed 15%.

Slight deviations from the above-mentioned requirements do not always prevent a particular recorder from being connected to the plotter-printer. Note that connecting a non-conforming recorder to the plotter-printer does not cause damage to the recorder or computer. If the recorder has a terminal which does not meet the requirement described above, use an appropriate converter plug available on the market. Note, however, that the requirements for the REMOTE terminal should be completely satisfied; otherwise, the remote function of FA-10 may be damaged.

Precautions for Connecting Tape Recorder

In order to ensure that the tape recorder connected to the FA-10 operates satisfactorily, note the following:

- Recorder jacks should be free of rust, cracks, etc.
 - Recorder head must not be stained or worn.
 - Tape used should have satisfactory frequency characteristic.
 - Tape should be free of scratches or folds. As far as possible, avoid using the leading and trailing portions of tape (for approximately 30 seconds of tape running).
 - If the tape recorder does not properly function on an AC power supply, use a battery.
 - Positively set the computer on the FA-10. When connecting or disconnecting the computer, be sure to turn off the power supply of the computer.
 - Use the same recorder for recording and reproduction. Data recorded on a tape recorder may not be properly reproduced on a different recorder.
 - Recorded tape should be preserved in good condition.
- Note: Poor storage condition may cause tape elongation, etc., which in turn may disable proper reproduction.
- When setting the computer on the FA-10, turn off the power supply of the computer and properly align the computer connector to the FA-10 connector.

Note: Touching the FA-10 connector by hand may cause poor contact due to deformation, stains, etc. It may also cause damage to the internal circuit due to static electricity. Never touch the connector by hand. When the FA-10 is not in use, be sure to put on the connector cap.

Preparations for Recording and Playback

■ Connecting the terminals

- Use the attached cables to connect terminals.
- Connect the MIC terminal of FA-10 to the recorder MIC terminal. (In the case of a stereo-recorder, it is desirable that the RIGHT terminal is used.)
- Connect the EAR terminal of FA-10 to the EAR, MONITOR, or EX SP terminal of the recorder. (In the case of a stereo-recorder, connect to the terminal that was used for recording.)
- Connect the REM terminal of FA-10 to the recorder REMOTE terminal.
- Although the three cables may be connected at the same time, some recorders produce noise when both the MIC and EAR terminals are connected. In this case, connect only the MIC terminal during recording (from the computer to tape), and connect only the EAR terminal during playback (from tape to the computer).

Input/Output terminals

- Connecting to an external tape recorder

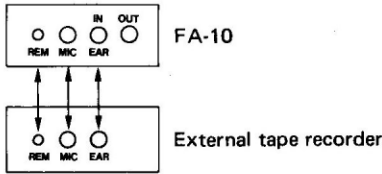

- Connecting two FA-10s

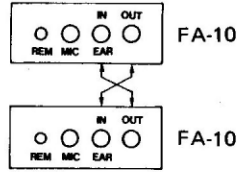

■ Adjusting recording level (during recording)

- Set the auto level control (if provided) to AUTO.
- For a recorder provided with a level adjusting knob, adjust the level to 0vu while recording dummy data, and use that level setting for recording actual data.

Note: If the level meter pointer swings the full span, avoid using the recorder.

■ Adjusting output level (during playback)

- The volume dial should be higher than when listening to music (generally, MAX is recommended).
- In the case of a stereo-recorder, the side to which the EAR terminal is connected should be set to MAX.
- For a recorder with mixing feature, set the SOURCE side to MAX and the MIC side to MIN.

■ Other adjustments

- Set TONE, BASS, and TREBLE to a medium level.
- Determine the TAPE SELECTOR according to the type of tape used.

WRITING/READING/CHAINING PROGRAM

■ Writing program

| |
|----------------------|
| SAVE |
| SAVE "file name" |
| SAVE "file name" ,A |
| SAVE ALL "file name" |

- (1) The file name consists of up to eight characters. It may be omitted.
- (2) When ,A is specified, the program is recorded in ASCII code format. If it is not specified, the program is recorded in internal code format (binary).
- (3) When ALL is specified, all program areas, P0–P9, are recorded simultaneously. ALL can be specified only for recording in binary format.
- (4) If a password has been established, the program is recorded with that password.

Operating procedure

The operating procedure is the same for the CM-1 and any external tape recorder. After setting the CM-1 to the FA-10 (or connecting the external tape recorder to the FA-10 with the attached cable), follow the sequence described below.

- (1) Set the computer POWER switch to ON and the CMT switch to ON. When a tape recorder with REMOTE terminal is used, set the REMOTE switch to ON. To monitor signal sound with the CM-1, set the MONITOR switch to ON.
- (2) Set the tape in its position and note down the number in the tape counter.
- (3) Start the tape recorder by pressing the REC button.
- (4) Execute the SAVE command.

Example: SAVE "CASIO" 

- (5) The program is written to the tape. The recorder automatically stops at the end of the program.
- (6) Press the STOP button on the tape recorder.

■ Reading program

| |
|----------------------|
| LOAD |
| LOAD "file name" |
| LOAD "file name" ,A |
| LOAD "file name" ,M |
| LOAD ALL "file name" |

- (1) The file name consists of up to eight characters. It may be omitted. If omitted, the program of the same format as the one encountered first is read.

Thus, Formats LOAD ← PFB (Program file, Binary)
 LOAD ALL ← AFB (All program files, Binary)
 LOAD ,A ← PFA (Program file, ASCII)
 LOAD ,M ← PFA (Program file, ASCII)

- (2) If the file format is different, the file name and format are displayed, but no program is read.
- (3) When ,A is specified, the program in ASCII code format is read.
- (4) When ,M is specified, the program in the currently specified program area is mixed with the program read in ASCII code format. In the mixing operation, the newly read program is given preference. Thus, if the same line number exists in both programs, the associated line of the newly read program remains.
- (5) When ,M is not specified, the current program is deleted and a program is newly read.
- (6) When ALL is specified, all the programs in P0–P9 are erased and a program is newly read.
- (7) If an RW error occurs during loading, be sure to execute the NEW command.
- (8) If the memory becomes full during read operation, an OM error occurs. In this case, execute the NEW command to clear the unnecessary program area, then reload the programs.
- (9) When the program loaded has a password, that password is set after the load operation is completed.
Note that the password of the program to be loaded is different from the password of the FA-10, that program cannot be loaded (PR error).
- (10) As a rule, use a tape recorder with the REMOTE terminal.

Reference: Display of file name

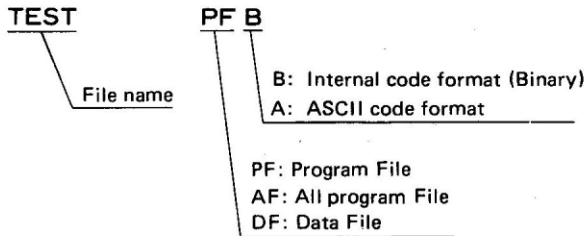

Operating procedure

- (1) Set the computer POWER switch and CMT switch to ON.
When a tape recorder with REMOTE terminal is used, set the REMOTE switch to ON. To monitor signal sound with the CM-1, set the MONITOR switch to ON.
- (2) Set the tape at a position slightly ahead of the position from which it was started for recording.
- (3) Press the PLAY button to start the tape recorder. if the REMOTE terminal is connected, the tape does not run.
- (4) Execute the LOAD command.

Example: LOAD "CASIO" 

- (5) The tape automatically stops at the end of the program.
- (6) Press the STOP button on the tape recorder.

■ Chaining program

| |
|-----------------------|
| CHAIN |
| CHAIN "file name" |
| 100 CHAIN "file name" |

- (1) When a CHAIN command written in a program is executed, the program is loaded from the tape and executed from the beginning.
- (2) When a new program is to be loaded, the current program is erased before the new program is loaded.
- (3) The file name consists of up to eight characters. It may be omitted. If omitted, the program having the same format as the one that is first encountered is loaded.
- (4) Only program having binary format can be loaded.
- (5) If the program to be loaded has a password, that password is set to the program after the load operation is completed.
If the password of the program to be loaded is different from the password of the FA-10, that program cannot be loaded (PR error).

Operating procedure

- (1) Set the computer POWER switch and CMT switch to ON.
When a tape recorder with REMOTE terminal is used, set the REMOTE switch to ON. To monitor signal sound with the CM-1, set the MONITOR switch to ON.
- (2) Set the recorded tape at a position slightly before the position from which it was started for recording.
- (3) Start the tape recorder by pressing the PLAY button.
- (4) Start the program in which the CHAIN command has been written.
- (5) When the CHAIN command is executed, the tape starts running. When the program has been read, it is executed from the beginning and the tape stops.
- (6) Press the STOP button on the tape recorder.
*The CHAIN command can also be used manually in the same manner as the LOAD command.

WRITING/READING DATA

■ Writing data

| |
|--|
| PUT |
| PUT "file name" variable |
| PUT "file name" variable [, variable]* |

The asterisk " * " indicates that variables can be written repeatedly.

- (1) The file name consists of up to eight characters. It may be omitted.
- (2) More than one variable can be specified by separating them with a comma (,).
- (3) All data is written in ASCII code format.

Operating procedure

- (1) Set the computer POWER switch and CMT switch to ON.
When a tape recorder with REMOTE terminal is used, set the REMOTE switch to ON. To monitor signal sound with the CM-1, set the MONITOR switch to ON.
- (2) Set the tape in its position and note the number in the tape counter.
- (3) Start the tape recorder by pressing the REC button.
- (4) Execute the PUT command for manual operation.

Example: PUT "TEST" A, B, C 

- (5) When the PUT command is written in a program, start that program.
- (6) After execution of the PUT command, the tape starts running. After the data has been written, the tape automatically stops.
- (7) Press the STOP button on the tape recorder.

■ Reading data

| |
|--|
| GET |
| GET "file name" variable |
| 200 GET "file name" variable [, variable]* |

The asterisk " * " indicates that variables can be written repeatedly.

- (1) The file name consists of up to eight characters. It may be omitted. If omitted, the data of the same format as the one encountered first is loaded.
- (2) More than one data item can be loaded by separating them with a comma (,).
- (3) When loading data into a numerical variable, numerals ("123", etc.) can be loaded as numeric values, but characters ("ABC", etc.) cannot be loaded (TM error).

Operating procedure

- (1) Set the computer POWER switch and CMT switch to ON.
When a tape recorder with REMOTE terminal is used, set the REMOTE switch to ON. To monitor signal sound with the CM-1, set the MONITOR switch to ON.
- (2) Set the recorded tape at a position slightly before the position from which it was started for recording.
- (3) Press the PLAY button to start the tape recorder.
- (4) Execute the GET command for manual operation.

Example: GET "TEST" A\$,B\$,C\$ 

- (5) When a GET command has been written in a program, start the program containing the GET command.
- (6) After execution of the GET command, the tape starts running. After the data has been loaded, the tape stops automatically.
- (7) Press the STOP button on the tape recorder.

CHECKING FILES

| |
|--------------------|
| VERIFY |
| VERIFY "file name" |

- (1) Performs parity check on programs and data written on tape.
- (2) The parity check verifies the recording format.
- (3) The file name consists of up to eight characters. It may be omitted. If omitted, the file encountered first is checked.
- (4) An incorrect parity causes an RW error.

Operating procedure

- (1) Set the computer POWER switch and CMT switch to ON.
When a tape recorder with REMOTE terminal is used, set the REMOTE switch to ON. To monitor signal sound with the CM-1, set the MONITOR switch to ON.
- (2) Set the recorded tape at a position slightly before the position from which it was started for recording.
- (3) Press the PLAY button to start the tape recorder.
- (4) Execute the VERIFY command.

Example: VERIFY "CHECK" 

- (5) After the check has been completed, the tape stops automatically.
- (6) Press the STOP button on the tape recorder.

COMMUNICATIONS BETWEEN TWO FA-10s

Program communication

- SAVE ALL and LOAD ALL are used for program communication.
- The sending side uses SAVE ALL, and the receiving side uses LOAD ALL.

Operating procedure

- (1) After connecting the FA-10s, set POWER switch and CMT switch to ON on both sides.
- (2) Execute a LOAD ALL command on the computer at the receiving side.

Example: LOAD ALL "PROG 1" 

└─ file name (may be omitted)

- (3) Execute a SAVE ALL command on the computer at the sending side.

Example: SAVE ALL "PROG 1" 

└─ file name (may be omitted; if specified, it must be the same as the file name specified at the receiving side.)

- (4) When the computer at the receiving side displays:

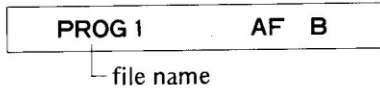

then the program is being read.

- (5) When "READY" is displayed on both computers, the program communication has been completed.

DATA COMMUNICATIONS

- PUT and GET are used for data communications.
- The sending side uses the PUT command, and the receiving side uses the GET command.

Operating procedure

- (1) After connecting the FA-10s, set the POWER switch and CMT switch to ON at the sending and receiving sides.
- (2) Execute a GET command on the computer at the receiving side.

Example: GET "DATA" A, B, C\$
└ file name (may be omitted)

- (3) Execute a PUT command on the computer at the sending side.

Example: PUT "DATA" A, B, C\$
└ file name (may be omitted; if specified, it must be the same as the file name specified at the receiving side.)

- (4) When the computer at the receiving side displays:

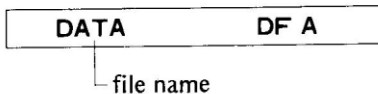

then, the data is being read.

- (5) When "READY" is displayed on both computers, the data communication has been completed.
 - * If the PUT command and the GET command are written in programs, execute those programs instead of performing steps 2 and 3, above.

CHARACTER CODE TABLE

| | 0 | 1 | 2 | 3 | 4 | 5 | 6 | 7 | 8 | 9 | A | B | C | D | E | F |
|---|-----|----|----|----|----|----|-----|-----|-----|-----|-----|-----|-----|-----|-----|-----|
| 0 | 0 | 16 | 32 | 48 | 64 | 80 | 96 | 112 | 128 | 144 | 160 | 176 | 192 | 208 | 224 | 240 |
| 1 | 1 | 17 | 33 | 49 | 65 | 81 | 97 | 113 | 129 | 145 | 161 | 177 | 193 | 209 | 225 | 241 |
| 2 | 2 | 18 | 34 | 50 | 66 | 82 | 98 | 114 | 130 | 146 | 162 | 178 | 194 | 210 | 226 | 242 |
| 3 | 3 | 19 | 35 | 51 | 67 | 83 | 99 | 115 | 131 | 147 | 163 | 179 | 195 | 211 | 227 | 243 |
| 4 | 4 | 20 | 36 | 52 | 68 | 84 | 100 | 116 | 132 | 148 | 164 | 180 | 196 | 212 | 228 | 244 |
| 5 | 5 | 21 | 37 | 53 | 69 | 85 | 101 | 117 | 133 | 149 | 165 | 181 | 197 | 213 | 229 | 245 |
| 6 | 6 | 22 | 38 | 54 | 70 | 86 | 102 | 118 | 134 | 150 | 166 | 182 | 198 | 214 | 230 | 246 |
| 7 | 7 | 23 | 39 | 55 | 71 | 87 | 103 | 119 | 135 | 151 | 167 | 183 | 199 | 215 | 231 | 247 |
| 8 | 8 | 24 | 40 | 56 | 72 | 88 | 104 | 120 | 136 | 152 | 168 | 184 | 200 | 216 | 232 | 248 |
| 9 | 9 | 25 | 41 | 57 | 73 | 89 | 105 | 121 | 137 | 153 | 169 | 185 | 201 | 217 | 233 | 249 |
| A | LF | 10 | 26 | 42 | 58 | 74 | 90 | 106 | 122 | 138 | 154 | 170 | 186 | 202 | 218 | 234 |
| B | ESC | 11 | 27 | 43 | 59 | 75 | 91 | 107 | 123 | 139 | 155 | 171 | 187 | 203 | 219 | 235 |
| C | FS | 12 | 28 | 44 | 60 | 76 | 92 | 108 | 124 | 140 | 156 | 172 | 188 | 204 | 220 | 236 |
| D | CR | 13 | 29 | 45 | 61 | 77 | 93 | 109 | 125 | 141 | 157 | 173 | 189 | 205 | 221 | 237 |
| E | | 14 | 30 | 46 | 62 | 78 | 94 | 110 | 126 | 142 | 158 | 174 | 190 | 206 | 222 | 238 |
| F | | 15 | 31 | 47 | 63 | 79 | 95 | 111 | 127 | 143 | 159 | 175 | 191 | 207 | 223 | 239 |

Note 1: Function codes

Any function codes other than CHR\$(0) (i.e., CHR\$(1) to CHR\$(31)) may be used as terminators. However, four of them are assigned the following special functions:

- (1) LF: Line feed (CHR\$(10))
Causes a CR/LF (carriage return and line feed) in character mode. This code is ignored when it immediately follows a CR (CHR\$(13)).
- (2) CR: Carriage return (CHR\$(13))
Causes a CR/LF (carriage return and line feed) in character mode.
- (3) ESC: Escape (CHR\$(27))
A character mode command indicator. This code is issued immediately before each character mode command in the graphic mode.
- (4) FS: File separator (CHR\$(28))
Causes switching between the character and graphic modes.

Note 2: Whereas the normal characters are represented in 4 x 6 proportions, “~” (CHR\$(126)) symbol is in 5 x 6 proportions and the graphic characters (CHR\$(128) to CHR\$(159) and CHR\$(224) to CHR\$(254)) are in 7 x 7 proportions. This should be kept in mind to ensure a proper separation between various characters.

* The graphic characters (CHR\$(128) to CHR\$(159) and CHR\$(224) to CHR\$(254)) appear slightly different from those which are printed in this manual. For their true fonts, see the character samples on the following pages.

CHARACTER SAMPLES

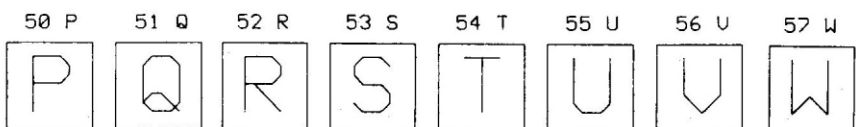
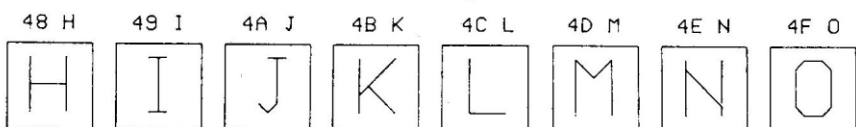
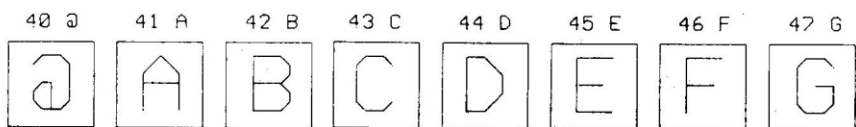
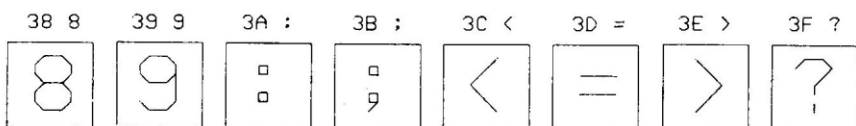
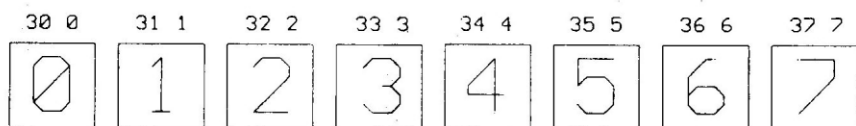
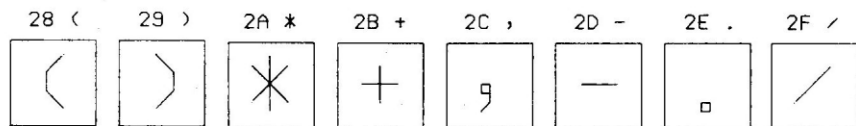
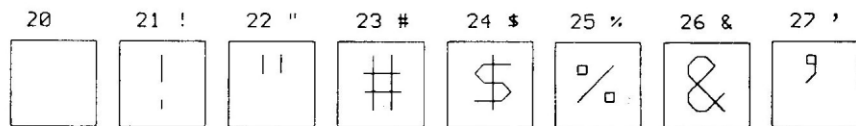

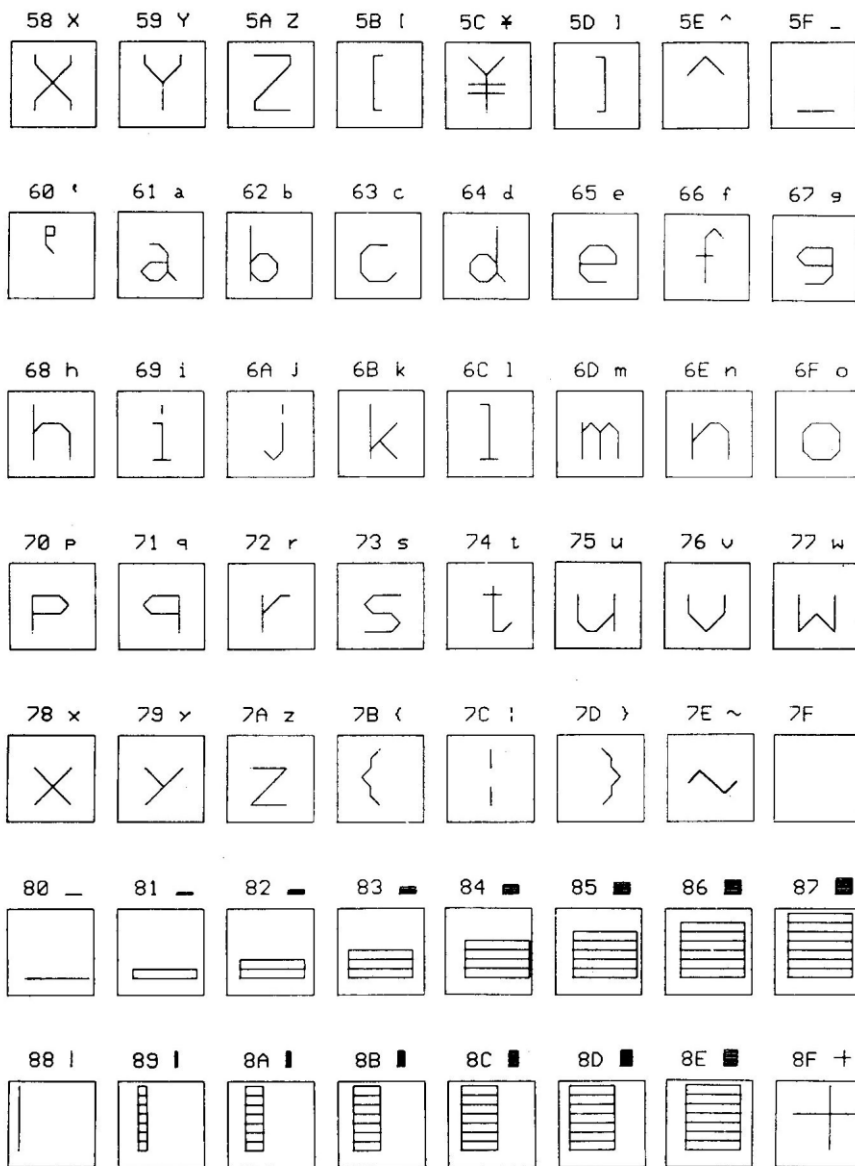

| | | | | | | | |
|------|------|------|------|------|------|------|------|
| 90 十 | 91 丁 | 92 十 | 93 卜 | 94 一 | 95 一 | 96 丨 | 97 丨 |
| | | | | | | | |
| 98 𠃍 | 99 𠃍 | 9A 𠃍 | 9B 𠃍 | 9C 𠃍 | 9D 𠃍 | 9E 𠃍 | 9F 𠃍 |
| | | | | | | | |
| A0 | A1 。 | A2 𠃍 | A3 𠃍 | A4 丶 | A5 。 | A6 ㄣ | A7 ㄣ |
| | | | | | | | |
| A8 彳 | A9 ㄣ | AA 彳 | AB ㄣ | AC 𠃍 | AD ㄣ | AE ㄣ | AF ㄣ |
| | | | | | | | |
| B0 一 | B1 ㄣ | B2 彳 | B3 ㄣ | B4 彳 | B5 ㄣ | B6 𠃍 | B7 𠃍 |
| | | | | | | | |
| B8 ㄣ | B9 ㄣ | BA 𠃍 | BB ㄣ | BC ㄣ | BD ㄣ | BE ㄣ | BF ㄣ |
| | | | | | | | |
| C0 ㄣ | C1 𠃍 | C2 ㄣ | C3 𠃍 | C4 卜 | C5 𠃍 | C6 二 | C7 𠃍 |
| | | | | | | | |

| | | | | | | | |
|------|------|------|------|------|------|------|------|
| C8 ㄛ | C9 ㄣ | CA ㄤ | CB ㄥ | CC ㄨ | CD ㄨ | CE ㄨ | CF ㄨ |
| | | | | | | | |
| D0 ㄨ | D1 ㄨ | D2 ㄨ | D3 ㄨ | D4 ㄨ | D5 ㄨ | D6 ㄨ | D7 ㄨ |
| | | | | | | | |
| D8 ㄨ | D9 ㄨ | DA ㄨ | DB ㄨ | DC ㄨ | DD ㄨ | DE ㄨ | DF ㄨ |
| | | | | | | | |
| E0 ㄨ | E1 ㄨ | E2 ㄨ | E3 ㄨ | E4 ㄨ | E5 ㄨ | E6 ㄨ | E7 ㄨ |
| | | | | | | | |
| E8 ♠ | E9 ♥ | EA ♦ | EB ♣ | EC ● | ED ○ | EE / | EF \ |
| | | | | | | | |
| F0 X | F1 円 | F2 年 | F3 月 | F4 日 | F5 時 | F6 分 | F7 秒 |
| | | | | | | | |
| F8 〒 | F9 市 | FA 区 | FB 町 | FC 村 | FD 人 | FE 田 | |
| | | | | | | | |

COMMAND TABLE (FOR PLOTTER-PRINTER)

| | Name | Command | Function | Page |
|------------------|-----------------|--|---|------|
| Drawing commands | ORIGIN ◦ | O [absolute X coordinate, absolute Y coordinate] (Term) | Defines an origin of ORG coordinate. | 21 |
| | DRAW ◦ | D [starting X coordinate, starting Y coordinate] [, X coordinate, Y coordinate] * (Term)
* At least one parameter must be present. | Draws straight lines connecting the points specified by ORG coordinates. | 22 |
| | RELATIVE DRAW ◦ | I X displacement, Y displacement [, X displacement, Y displacement] * (Term) | Draws straight lines connecting the points defined by the specified displacements in X and Y directions from the current pen position. | 23 |
| | MOVE ◦ | M [X coordinate], [Y coordinate] (Term) | Moves the pen holder assembly with the pen up to the point defined by the specified ORG coordinates. | 24 |
| | RELATIVE MOVE ◦ | R X displacement, Y displacement (Term) | Moves the pen holder assembly with the pen up from the current pen position to the point defined by the specified X and Y displacements. | 25 |
| | QUAD-RANGLE ◦ | A starting X coordinate, starting Y coordinate, diagonal X coordinate, diagonal Y coordinate (Term) | Draws a quadrangle whose two diagonal points are defined by the two specified ORG coordinates and whose sides are parallel to the X and Y axes. | 26 |
| | CIRCLE ◦ | C [X center coordinate, Y center coordinate], radius [, initial arc angle, final arc angle] (Term)
* final arc angle > initial arc angle | Draws a circle or circular arc around the center defined by the specified ORG coordinates. It draws an arc when the angle parameters are specified. | 27 |
| | AXIS ◦ | X axis direction, size of scale division, number of scale divisions (Term)
* $0 \leq \text{axis direction} < 4$, size of scale division > 0, number of scale divisions > 0 | Draws a coordinate axis in the +Y, +X, -Y, or -X direction from the origin of ORG coordinate. | 29 |

| | | | | |
|--|--|--|--|----|
| Character and symbol printing commands | GRID ○ | G direction of stripes, range in X axis direction, range in Y axis direction [, stripe separation] (Term)
* $0 \leq \text{direction of stripes} < 3$,
stripe separation > 0 | Draws horizontal or vertical stripes from the current pen position within the specified range. | 30 |
| | LINE TYPE ○ | L line type (Term)
* $0 \leq \text{line type} < 4$ | Specifies a line type which is solid line, broken line, one-dot chained line or two-dot chained line. | 31 |
| | LINE SCALE ○ | B line pitch (Term)
* broken line pitch ≥ 0 | Specifies the pitch of broken line, one-dot chained line or two-dot chained line. | 32 |
| | ALPHA SCALE ○ | S character scale (Term)
* $0 \leq \text{character scale} < 10$ | Specifies the size of characters and symbols to be printed. | 33 |
| | ALPHA ROTATE □ | Q rotational angle (Term)
* $0 \leq \text{rotational angle (orientation)} < 4$ | Specifies the rotational angle (orientation) of characters and symbols to be printed. | 34 |
| | SPACE ○ | Z spacing between current and next characters [, spacing between current and next lines] (Term) | Specifies the spacing between the current and next characters and/or the spacing between the current and next lines. | 35 |
| | HORIZONTAL/VERTICAL PRINT ○ | Y horizontal/vertical selection (Term)
* $0 \leq \text{horizontal/vertical selection} < 2$ | Specifies whether subsequent character strings are to be printed horizontally or vertically. | 37 |
| PRINT □ | P character string (Term) | Allows the specified character strings or data to be printed while in graphic mode. | 38 | |
| MARK ○ | N mark number (Term)
* $0 \leq \text{mark number} < 10$ | Draws the specified mark centered at the current pen position. | 39 | |
| Control commands | NEW PEN ○ | J color of pen (Term)
* $0 \leq \text{color of pen} < 4$ | Specifies the color of pen; black, blue, green or red. | 40 |
| | LINE FEED ○ | F number of lines (Term) | Feeds the paper by the specified number of lines. | 41 |
| | HOME ○ | H [distance from foremost drawing-point] (Term)
* distance from foremost drawing-point ≥ 0 | Redefines the absolute coordinate system, or moves the pen holder assembly for inspection of the drawing. | 42 |
| | TEST ○ | Ⓢ (CHR\$ (64)) (Term) | Allows trial drawing or a check for proper inking. | 43 |

| | | | | |
|----------------------------|-----------------|---|--|----|
| Character control commands | TAB Δ | T number of print positions (Term) | Specifies a tab position. | 44 |
| | FORMAT Δ | ? $\begin{Bmatrix} 0 \\ 1 \end{Bmatrix}$ (Term) | Specifies a formatted program listing. | 45 |

- Note 1) ● An asterisk “*” indicates that the term preceding it may appear more than once.
- Braces “{ }” indicate that at least one of the parameters enclosed within them must be specified.
 - Brackets “[]” indicate that the parameters enclosed within them may be omitted.
 - All the parameters are real numbers with up to 3 digit integers; any fractional part must be a multiple of 0.2 unless otherwise specified. I.e., the range is from -999.8 to 999.8.

- Note 2) ● A “○” mark indicates that the command is effective in both the character and graphic modes.
- A “ Δ ” mark indicates that the command is effective only in the character mode.
 - A “□” mark indicates that the command is effective only in the graphic mode.

ERROR MESSAGES

| Error message | Type of error | Explanation |
|---------------|------------------|---|
| C-ERR '~~~~' | Command errors | An undefined command was issued. The command format was incorrect, or the command was improperly used. |
| P-ERR '~~~~' | Parameter errors | The command contains an illegal number of parameters. The parameter format is incorrect. The parameters exceed the allowable range. |
| M-ERR | Mode errors | A command code other than "." (CHR\$(46)) and "%" (CHR\$(37)) was sent immediately after an FS(CHR\$(28)) in either mode. An illegal mode specification was performed. |
| O-ERR | Overrun errors | The absolute coordinate area (-6553.4, -6553.4) to (6553.4, 6553.4) was exceeded during the execution of a command, or an attempt was made to feed the paper backward more than 6553.4 from the foremost drawing point. |

* Command and parameter error messages are followed by the name of the command in which an error was detected, as indicated by '~~~~'.

** One of the most probable causes of the above errors is an incorrect command format (i.e., bad syntax). Recheck the program list.

SPECIFICATIONS

■ Plotter-printer

| | |
|---------------------------------------|---|
| Printing method | Ball-point pens in rotary pen holder assembly (black, blue, green, and red). |
| Drive configuration | Drum type X-Y plotter. |
| Character types | 159 characters
63 graphic characters
Total: 222 |
| Number of printed characters per line | Max. 80 (ALPHA SCALE 0)
Normal 40 (ALPHA SCALE 1)
Min. 8 (ALPHA SCALE 9)
* Character spacing adjustable. |
| Character size | 10 different sizes (specified by program). |
| Printing speed | Average 11 characters/sec. (ALPHA SCALE 0). |
| Step speed | 260 steps/sec. |
| Step size | X axis: 0.2 mm, Y axis: 0.2 mm. |
| Plottable range | X axis: 96 mm (480 steps).
Y axis: No limit in the negative direction.
200 mm in the positive direction. |
| Paper | Fine-quality paper PRP-24 (24 mm ϕ), PRP-70 (70 mm ϕ)
Width 114.5 mm \pm 0.2 mm
Max. roll diameter 70 mm (Built-in paper roll: 24 mm)
Thickness 0.07 mm \pm 0.005 mm |
| Ball-point pen | Water-color ink BP-1 (black, blue, green and red),
BP-2 (black x 4)
Size 5 mm ϕ x 23.3 mm
Plotting length Approx. 250 m/pen
Colors 4 colors (black, blue, green and red) |

■ **Cassette interface**

| | |
|--------------------------------|---|
| Output terminals | OUT (3.5 mm ϕ) – output impedance: approx. 10k Ω ,
output level: 3.5–5V |
| | MIC (3.5 mm ϕ) – output impedance: approx. 40k Ω ,
output level: 3–5mV |
| Input terminal | EAR (3.5 mm ϕ) – input impedance: approx. 20k Ω ,
input level: 2.5–50V |
| Remote control terminal | REM (2.5 mm ϕ) – 24V, 1A or less |
| Recording method | Kansas City standards (300BPS) |

■ **Common section**

| | |
|---|--|
| Power source | Built-in rechargeable battery or AC adaptor (AD-5480). |
| Power consumption | Max. 15W |
| Battery life
(continuous operation
when the battery is
fully charged) | Plotter-printer – approx. 1,500 lines (20 characters/line)
Microcassette tape recorder – approx. 12 hours |
| Ambient temperature range | 0°C – 40°C (32°F – 104°F) |
| Dimensions | 45 mmH x 297 mmW x 210 mmD
(1 $\frac{3}{4}$ "H x 11 $\frac{5}{8}$ "W x 8 $\frac{1}{4}$ "D) |
| Weight | 1.34 kg (3 lbs) |

CASIO®